

**James Walker**<sup>®</sup>

# Hydraulic Sealing Guide

Issue 28.1

- *Rod/gland seals*
- *Piston seals*
- *Wipers & scrapers*
- *Bearing strips*
- *'O' rings*



High Performance Sealing Technology



## Introduction

### Hydraulic sealing products

**James Walker's family of hydraulic sealing products is all embracing. We provide well proven products that are designed for applications ranging from delicate instruments and control actuators right up to the heaviest forging and extrusion presses.**

Each product has been specifically developed to give you:

- Optimum equipment performance.
- Reduced leakage.
- Low-friction operation.
- Long trouble-free working life.



### Complete family

We use the term *hydraulic sealing products* to describe the wide variety of devices used to assist and perform the sealing function in all types of hydraulic and associated equipment that help to provide dynamic reciprocating, oscillating or very slow rotational motion.

Nowadays, hydraulic cylinders, and their associated control component assemblies, appear in numerous forms and sizes depending on the duties they must perform. Whatever your application, there will be a fundamental requirement for our:

**Rod/gland seals** — to seal around the reciprocating rod or ram.

**Piston seals** — to seal between the reciprocating piston and cylinder bore.

**Wipers, scrapers or protector bellows** — where the ingress of external contaminants such as dust, dirt or water must be eliminated.

**Bearing strips** — to provide support to the piston or ram under lateral loads.

### Family support

We provide all these hydraulic sealing products, and back them with:

- Top level technical support worldwide by local hydraulics sealing experts — backed by industry specialists and the leading-edge skills and knowledge of James Walker Technology Centre.
- A vast range of standard sizes for all our hydraulic sealing products. This document contains general information on sizes. For the full size ranges please refer to our sister publication *Hydraulic sealing products — Size charts*, which can be downloaded in pdf format from [www.jameswalker.biz](http://www.jameswalker.biz).
- Standard materials suitable for the majority of applications, plus special materials for specific duties.
- Ex-stock or short lead-time availability for products to national and international standards.
- Express manufacture of specials, to help get your hydraulic plant back into operation with the minimum of downtime.

### How to use this guide

**Page 5:** We suggest you initially turn to this page for our *Hydraulic seal selection guide*. This will lead you through the parameters that should be considered.

**Pages 6-9:** Then go to our *Quick reference chart*. This presents an overview of our hydraulic products and gives a brief description of each, plus a page reference for detailed information on your selected items. A convenient fold-out version of this chart is attached to the rear cover.

**Rod/gland seals:** pages 10-28 ●  
**Piston seals:** pages 10-19 & 29-34 ●  
**Special duty products:** pages 35-39 ●  
**Wipers & scrapers:** pages 40-44 ●  
**Bearing strips:** pages 45-46 ●  
**Ram protectors:** page 47 ●  
**'O' rings:** page 48 ●

**Chemical compatibility:** pages 50-51  
**Machining information:** pages 52-53

**Appendices:**  
Preferred housing designs: pages 54-76 ●  
Housing standards: pages 77-82 ●

**Technical guides:** page 83  
**Quick reference fold-out:** page 84  
**Alphabetical index:** page 85  
**General information:** page 85  
**James Walker contacts worldwide:** page 86.

## About James Walker



### Worldwide network & supply

James Walker is a dynamic global manufacturing organisation that supplies a vast range of specialised products and services to virtually every industrial sector. Our development work in fluid sealing technology started in the 1880s, swiftly followed by our products and materials achieving worldwide recognition.

Today, a close-knit network of James Walker companies and official distributors covers over 100 countries. This is supported by a secure web-based and highly developed logistics operation to give you surety of supply for your:

- Just-in-time (JIT) regimes.
- Normal maintenance schedules.
- Emergency breakdowns.

We stock many thousands of different sealing products ready for same day despatch.

If we do not stock the seals you need, we can supply them within days — rather than weeks. This we achieve because we compound our elastomers in-house and operate flexible manufacturing systems at our production plants, working within a tightly controlled 'lean' environment.

When necessary, production time-scales can be reduced to just hours to help you get your plant back into operation.

### Customer support

Our role is to provide you with the very best:

- Customer support.
- Technical support.
- Hydraulic sealing products.
- Delivery.
- After sales service.

James Walker's Customer Support Centre leads the fluid sealing industry with its service to tens of thousands of customers worldwide.

At a local level, on-site technical advice comes from our teams of sealing experts, backed by highly skilled applications engineers and industry specialists, plus the top-level research and development capabilities of the James Walker Technology Centre.

Together, they have the knowledge and facilities to solve any fluid sealing problem for our customers.

### Quality — the prime factor

The process we select to produce your hydraulic sealing components is ruled by customer satisfaction rather than our own ease of manufacture.

We select the best raw materials for each product and use advanced manufacturing techniques with strict quality control at every stage.

This culminates in an exacting inspection procedure for the finished product, using state-of-the-art techniques in addition to traditional methods undertaken by skilled personnel.

James Walker's stockholding and logistics operations meet similar exacting quality standards.

Our quality systems are third-party registered to BS EN ISO 9001 and BS EN 9100. We are also regularly assessed and quality approved by a wide range of industry bodies and individual customers, including multinational corporations, utilities and government organisations.

## About James Walker

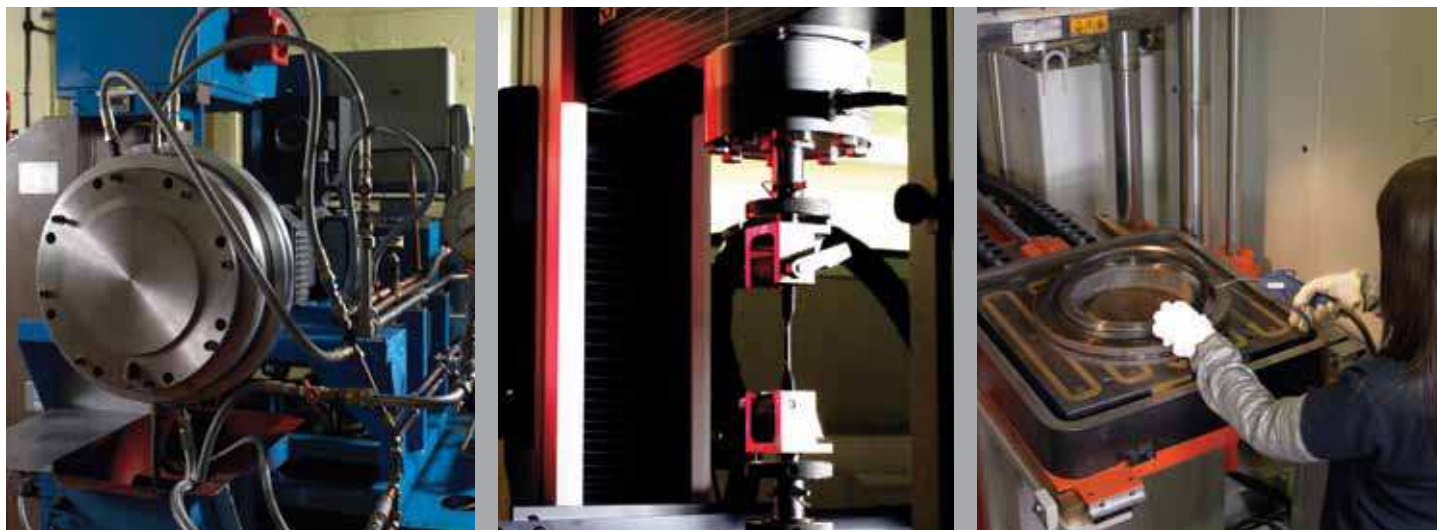

### Production facilities

Our manufacturing plants for elastomeric seals are located in the UK, USA and Australia. These, together with other production facilities around the world, ensure we provide industries at all levels with top quality engineered solutions for their sealing problems.

Our in-house facilities include:

- Injection moulding to 500mm (19.7 inch) diameter.
- Compression moulding to 2.2m (87 inch) diameter in a single operation with one of the biggest presses for precision moulding in Europe.
- Vacuum moulding to 2.1m (83 inch) diameter in a single operation.
- Special production techniques that enable the manufacture of seals to unlimited diameter.
- Transfer moulding.
- CAD/CAM design and auto-machining of mould tools.
- Rubber-to-metal bonding, with degreasing, acid etching and phosphating of metal surfaces.
- CNC centre for machining engineering plastics and elastomers.
- Elastomer impregnation of fabrics and fibres for production of specialised composite materials.
- Batch compounding of over 300 elastomer grades — with interlocked energy, time and temperature control for QA traceability.

### Research & development

Scientists and development engineers at the James Walker Technology Centre work constantly at the leading edge of fluid sealing knowledge and materials science.

They deliver the new materials, products and manufacturing techniques that improve the sealing of today's industrial plant and meet tomorrow's sealing demands before they arise.

Custom design and manufacture is a James Walker speciality. If a standard product will not solve your problem, we have the in-house facilities to innovate, design, prototype, develop and test hydraulic sealing systems specifically to match your operational parameters.

We also work on joint venture research projects with other organisations in the European Sealing Association — of which we are a founder member — and sponsor high-level research in partnership with world leading users of sealing technology.

In addition to our in-house test laboratories that verify the integrity of our materials and seal designs, we regularly commission independent test houses across the world for third-party certification of our products to international and industry standards.

## Hydraulic seal selection guide

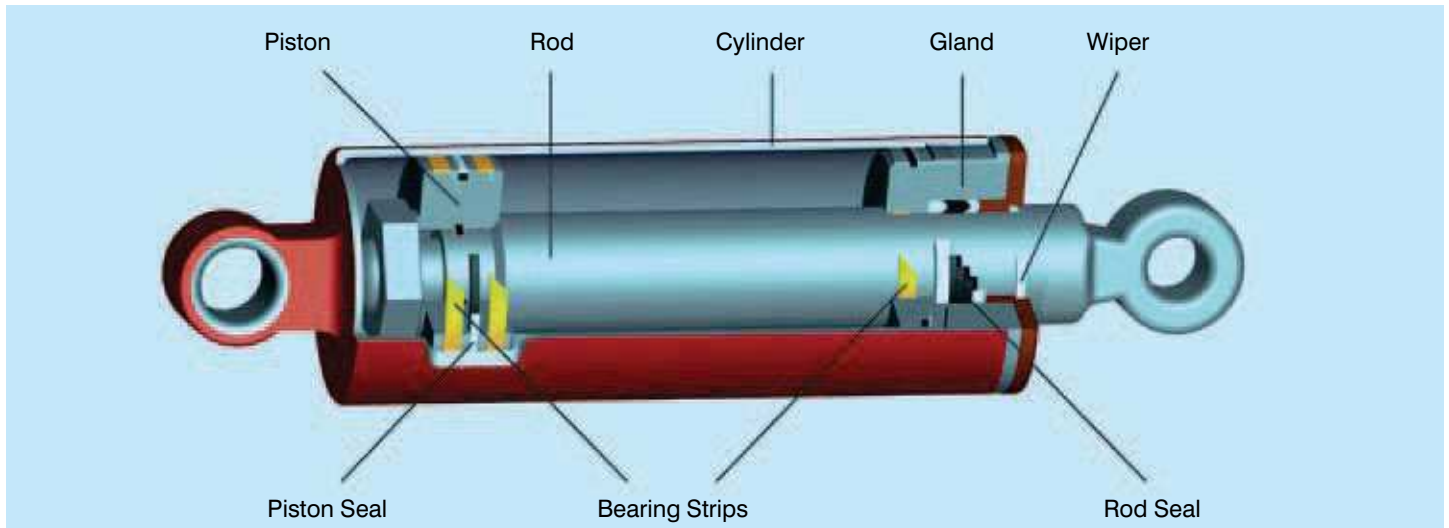
Six simple steps  
to seal selection

To select the correct hydraulic seal for your application, please consider the following steps.

**Step 1: Seal function**

The seal you require will usually be for the rod, ram, gland or piston — and you may also require wipers or bearing strips.

Please look first at our *Quick reference chart* (pages 6-9). Select the most appropriate seals and then go to the pages quoted for full descriptions and size availabilities. A convenient fold-out version of this chart is attached to the rear cover.

**Step 2: Sealing method**

Depending on your application, you may require single, double or multi-lip sealing.

Fine tune your selection of possible seals by considering the method of sealing required. For example, it could be the single action of our *Solosele® G*, the double action of *Lionsele® P*, or the multi-lip sealing action of a *Chevron®* set.

Note that single-acting seals (eg, *Solosele G*) may be used in a back-to-back arrangement in separate housings on double-acting piston assemblies.

**Step 3: Operational parameters**

The maximum pressure of the application should be considered along with the temperature range in which it will operate.

Reciprocating speed also needs to be considered: the standard maximum cylinder stroke speed is 0.5m/s, with some of our seals rated higher. If your application requires higher speeds than the seal you have selected, then please consult our Technical Support Team.

Stroke length should also be considered when calculating the seal depth: stroke length divided by 2.5 is the maximum recommended seal depth — otherwise fluid film lubrication may be compromised.

**Step 4: Material compatibility**

To determine that the seal materials are compatible with your system media, please check the *Materials of construction* and *Media capabilities* as stated in the seal's full description.

You can also cross-reference the materials and media on our *Chemical compatibility* chart on pages 50-51. If in doubt please consult our Technical Support Team.

**Step 5: Operational features**

Please consider and check availability of your seal for the following:

**Endless:** this is our preferred method of supply, as it provides the highest sealing integrity.

**Split-type:** for easier and quicker installation during plant maintenance.

**Step 6: Sizing the seal**

Refer to the section drawings for the required housing measurements, then check the standard listings charts for the JW Order Code in our sister publication *Hydraulic sealing products — Size charts* (this can be downloaded in pdf format from [www.jameswalker.biz](http://www.jameswalker.biz)).

If the size you require does not appear, please consult our Customer Support Centre or your local James Walker company for a quotation.

**Note:** Prior to sizing your seals, please check the condition of the rod, gland, housing, etc. Ensure all plant components meet manufacturer's recommendations, such as surface finish.

For more information, please refer to *Machining information* (pages 52-53) and *Housing details* (pages 54-82).

# Quick reference chart

## Overview of products

### Rod/gland seals

Chevron®  
Lion® Expanding Packing  
Lionsele® G  
Lionsele® LF  
Lionsele® U1  
Lionsele® U2  
Lofilm®  
Lofilm® HD  
Solosele® G  
Twinset  
U-rings

### Piston seals

Chevron®  
Lionsele® LF  
Lionsele® P  
Lionsele® SP  
Lionsele® U1  
Lionsele® U3  
Solosele® G  
Solosele® S  
Solosele® SW  
Twinset  
U-rings

### Special duty

Composite seals  
Self-aligning Gland Rings  
Solosele® KB Hydro  
Tube test seals

### Wipers

Lionsele® W1  
Lionsele® W2  
Lionsele® W3  
Wiper Type L  
Wyclip®

### Bearing strips

Lionsele® B1  
Lionsele® B2

### Ram protectors

Complex® Bellows

### 'O' rings

Virtually all standards & sizes

*Note: Statements of operating limits quoted are not an indication that these values can be applied simultaneously.*

## Key to materials

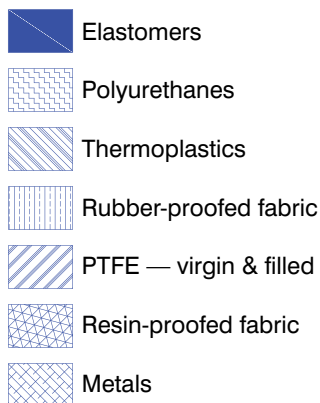

### Chevron® Rod/gland seal Piston seal

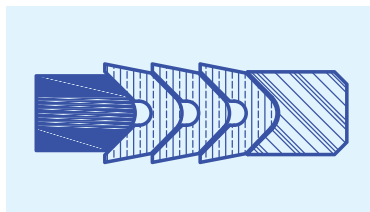

#### Universally proven multi-lip packing

Max operating pressure: 42MPa  
Max surface speed: 0.5m/s  
Temperature range: -20°C to +100/120°C  
Supplied: Split & endless

*Details: P10-11 + Appendix A*

### Solosele® G Rod/gland seal Piston seal

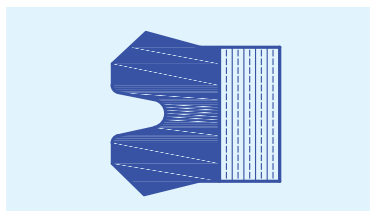

#### Robust single element seal

Max operating pressure: 42MPa  
Max surface speed: 0.5m/s  
Temperature range: -20°C to +120°C  
Supplied: Endless

*Details: P12-13 + Appendix B*

## Twinset

### Rod/gland seal Piston seal

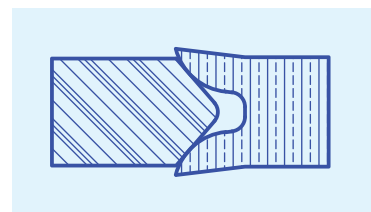

#### Decades of duty on older plant

Max operating pressure: 34MPa  
Max surface speed: 0.5m/s  
Max temperature: +100°C  
Supplied: Endless

*Details: P14-15 + Appendix C*

### Lionsele® LF Rod/gland seal Piston seal

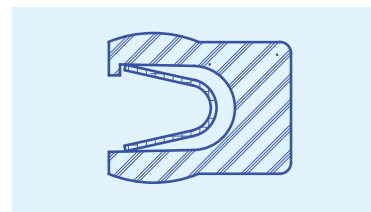

#### Very low friction: smoothest operation

Max operating pressure: 40MPa  
Maximum surface speed: 5.0m/s  
Temperature range: -250°C to +260°C  
Supplied: Endless

*Details: P16-17 + Appendix D*

### Lionsele® U1 Rod/gland seal Piston seal

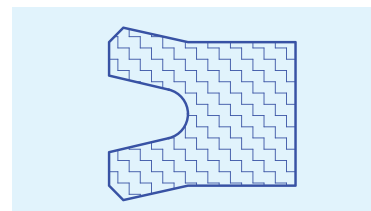

#### Ideal for aggressive environments

Max operating pressure: 42MPa  
Maximum surface speed: 0.5m/s  
Temperature range: -30°C to +100°C  
Supplied: Endless

*Details: P18 + Appendix E*

# Quick reference chart

**U-rings**  
**Rod/gland seals**  
**Piston seals**

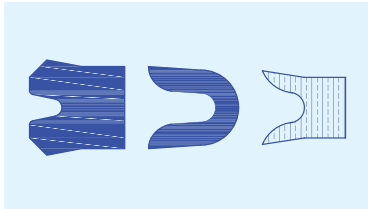

**Operating capabilities:** Depend on design and materials of construction. Supplied in a variety of elastomers and rubberised fabrics.

*Details: P19*

**Lofilm® HD**  
**Rod/gland seal**

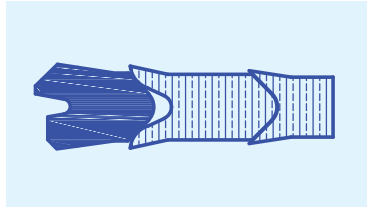

**For forging & extrusion presses**  
 Max operating pressure: 62MPa  
 Max surface speed: 0.5m/s  
 Temperature range: -20°C to +120°C  
 Supplied: Split & endless

*Details: P24-25 + Appendix H*

**Lionsele® SP**  
**Piston seal**

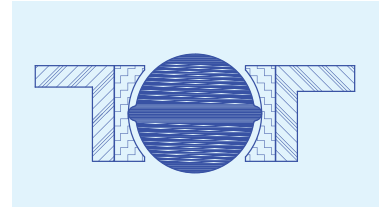

**Double-acting, for spool-type pistons**  
 Max operating pressure: 42MPa  
 Maximum surface speed: 0.5m/s  
 Temperature range: -20°C to +100°C  
 Supplied: Endless

*Details: P29 + Appendix J*

**Lofilm®**  
**Rod/gland seal**

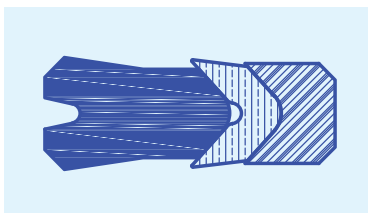

**Highly versatile multi-lip seal**  
 Max operating pressure: 42MPa  
 Max surface speed: 0.5m/s  
 Temperature range: -20°C to +120°C  
 Supplied: Split & endless

*Details: P20-21 + Appendix F*

**Lionsele® G**  
**Rod/gland seal**

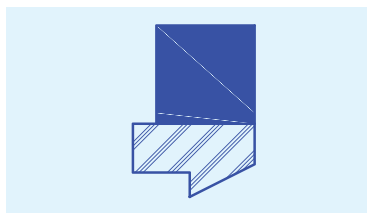

**High performance, single-acting**  
 Max operating pressure: 40MPa  
 Max surface speed: 5.0m/s  
 Temperature range: -25°C to +120°C  
 Supplied: Endless

*Details: P26-27 + Appendix I*

**Lionsele® P**  
**Piston seal**

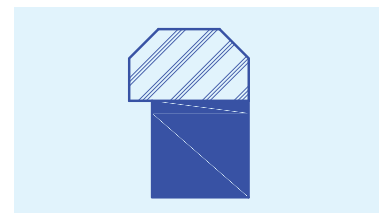

**High performance, double-acting seal**  
 Max operating pressure: 40MPa  
 Max surface speed: 5.0m/s  
 Temperature range: -25°C to +120°C  
 Supplied: Endless

*Details: P30-31 + Appendix K*

**Lion® Expanding Packing**  
**Rod/gland seal**

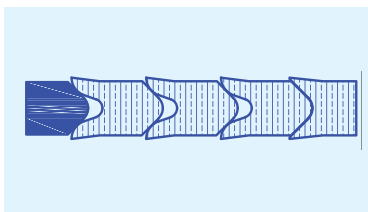

**Robust multi-lip packing**  
 Max operating pressure: 62MPa  
 Max surface speed: 0.5m/s  
 Temperature range: -20°C to +100°C  
 Supplied: Split & endless

*Details: P22-23 + Appendix G*

**Lionsele® U2**  
**Rod/gland seal**

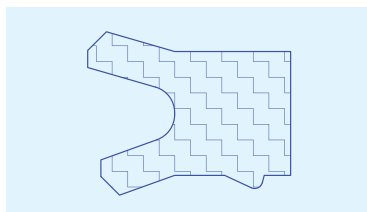

**Single-acting seal in polyurethane**  
 Max operating pressure: 42MPa  
 Maximum surface speed: 0.5m/s  
 Temperature range: -30°C to +100°C  
 Supplied: Endless

*Details: P28 + Appendix E*

**Solosele® S**  
**Piston seal**

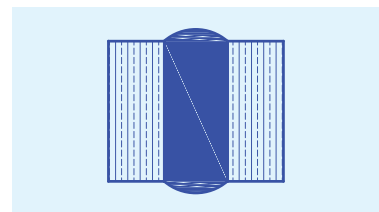

**For split-type piston heads**  
 Max operating pressure: 42MPa  
 Max surface speed: 0.5m/s  
 Temperature range: -20°C to +120°C  
 Supplied: Endless

*Details: P32 + Appendix L*

## Quick reference chart

### Solosele® SW Piston seal

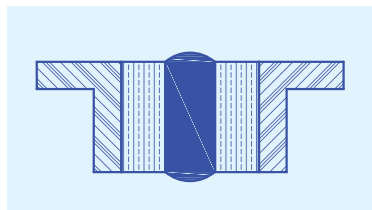

#### **Robust double-acting seal**

Max operating pressure: 42MPa  
Max surface speed: 0.5m/s  
Temperature range: -20°C to +100°C  
Supplied: Endless

Details: P33 + Appendix M

### Solosele® KB Hydro Special duty seals

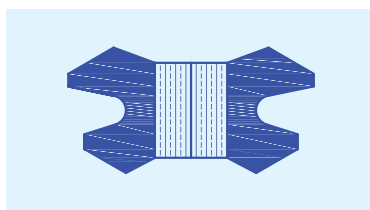

#### **Blade root seal for Kaplan turbines**

Cost effective, long-term sealing on slow oscillating duties associated with Kaplan water turbines.

Supplied: Endless & OSJ®  
(On-Site Joining)

Details: P36-37

### Lionsele® W1 Wiper

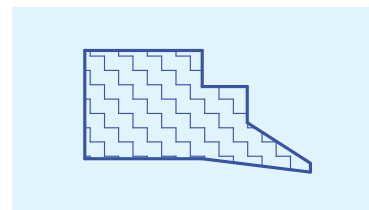

#### **Medium duty wiper for sand & mud**

Temperature range: -30°C to +100°C  
Supplied: Endless  
High performance polyurethane wiper with excellent wear resistance.

Details: P40 + Appendix O

### Lionsele® U3 Piston seal

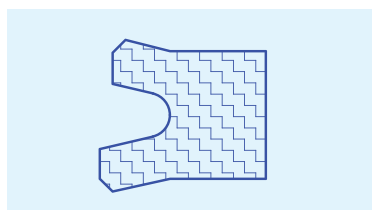

#### **Reduces risk of inter-seal pressure**

Max operating pressure: 42MPa  
Maximum surface speed: 0.5m/s  
Temperature range: -30°C to +100°C  
Supplied: Endless

Details: P34 + Appendix E

### Tube test seals Special duty seals

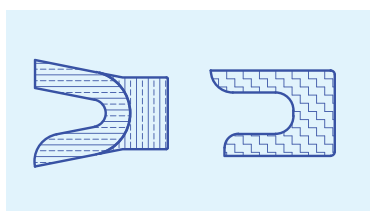

#### **For hydrostatic testing**

Maximum operating pressures:  
Polyurethane versions: 100MPa  
Rubberised fabric versions: 69MPa

Supplied: Endless  
Used on tube testing machines that seal and release repeatedly.

Details: P38

### Lionsele® W2 Wiper

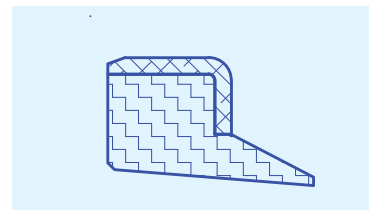

#### **Medium-to-heavy duty wiper**

Temperature range: -30°C to +100°C  
Supplied: Endless  
Metal-cased polyurethane wiper. Self-retaining design for open-faced housings.

Details: P41 + Appendix P

### Composite seals Special duty seals

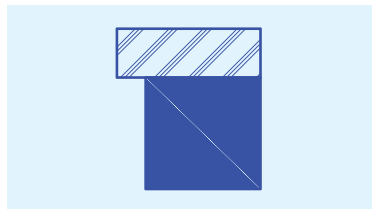

#### **Custom-designed & manufactured**

Combine compactness with low break-out and dynamic friction for instant response on customer-specific hydraulic and pneumatic control systems.  
Supplied: Endless

Details: P35 + Appendix N

### Self-aligning Gland Rings Special duty — optional feature

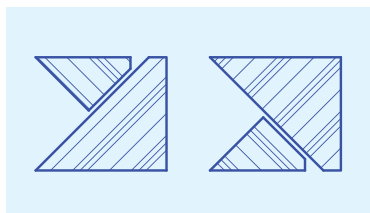

#### **Recommended for arduous conditions**

For Chevron®, Lion® Expanding Packing, Lofilm® and Lofilm® HD seals when used with heavily worn rams, shafts with large offset, and systems with extrusion gaps.

Details: P39

### Lionsele® W3 Wiper

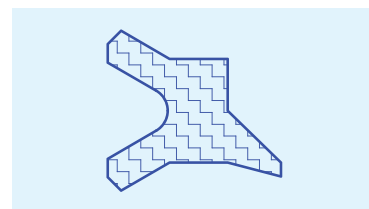

#### **Double-acting wiper**

Temperature range: -30°C to +100°C  
Supplied: Endless  
Polyurethane wiper with chamfered lips designed to prevent dirt ingress and control fluid film build up.

Details: P42 + Appendix Q



# Quick reference chart

Wyclip®  
Scraper/wiper

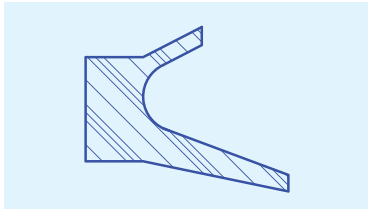

**Heavy duty scraper/wiper**

Temperature range: -40°C to +100°C  
Supplied: Endless  
A simple design of clip-in wiper that is widely used on hydraulic actuators.

Details: P43 + Appendix R

Lionsele® B2  
Bearing strip

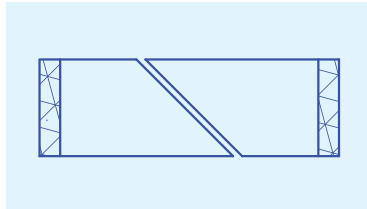

**For heavy duty applications**

Max bearing stress (static; RT): 400MPa  
Max bearing stress (dynamic; RT): 90MPa  
Max relative speed: 1.0m/s.  
Temperature range: -60°C to +100°C  
Supplied: Strip form or machined bearing.

Details: P46 + Appendix T

'O' rings  
Highly versatile seals



**Many thousands of types and sizes**

BS ISO 3601-1 (metric & inch).  
BS 1806 (inch: now superseded by BS ISO 3601-1 Class A).  
SAE AS 586 (inch).  
BS 4518 (metric).

Stocked material grades include:  
Nitrile rubber (NBR).  
Elast-O-Lion® hydrogenated nitrile (HNBR) including RGD resistant.  
Ethylene-propylene (EPM).  
Silicone rubber (VMQ).  
Fluoroelastomer (FKM), including RGD resistant.

Details: P48

Wiper Type L  
Wiper

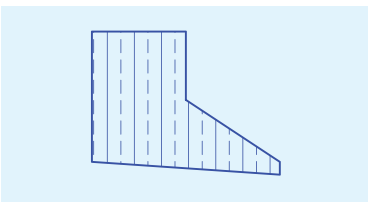

**Wiper for highly abrasive media**

Temperature range: -35°C to +120°C  
Supplied: Split & endless  
Robust and wear-resistant wiper of tough rubberised fabric construction.

Details: P44 + Appendix S

Comflex® Bellows  
Ram protectors

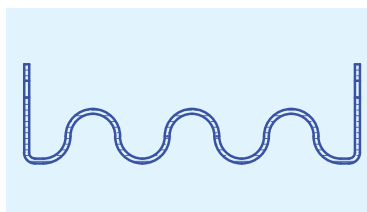

**Robust, heavy-duty protection**

Fabric-reinforced elastomeric bellows of fully vulcanised construction. Protect rams working in aggressive environments on forging presses, pulverising mills, etc.

Details: P47

Lionsele® B1  
Bearing strip

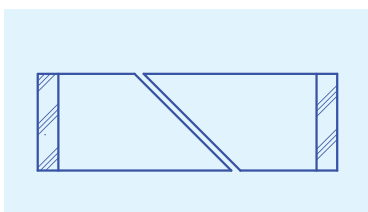

**Bronze-loaded PTFE for low friction**

Max bearing stress (static; RT): 25MPa  
Max bearing stress (dynamic; RT): 12MPa  
Max relative speed: 5.0m/s  
Temperature range: -60°C to +150°C  
Supplied: Strip form or machined bearing.

Details: P45 + Appendix T

# Chevron® for rods/glands & pistons

Chevron®  
Universally proven multi-lip packing

### Description

Chevron® (known as *Shallex*® in some regions) is our universal multi-lip packing set that is highly regarded for its long working life and ability to operate under adverse mechanical conditions. When used in split form it can provide major downtime savings.

This robust packing set comprises a gland ring/female adapter, header/male adapter, and one or more intermediate V-shaped rings. The rings are tapered to give an initial interference fit when confined in the seal housing. The resulting radial force together with the fine finish of the lip, ensure a good seal at low or slack pressures. A scarf abutment is used when the seal is needed in split form.

### Special features

- Double-acting capabilities when fitted back-to-back.
- Recommended for safety critical duties and adverse mechanical conditions.
- Excellent extrusion and wear resistance.
- Options available to suit adjustable and non-adjustable axial housing lengths.
- Available with **Self-aligning Gland Ring** (see page 39).

### Typical applications

**Standard materials:** most types of hydraulic press (main rams and drawback rams); hydraulic cylinder glands and piston heads; hydraulic valves; oil pipeline expansion glands.

**Special materials:** reciprocating steam, water, boiler feed and oil pumps; hot oil reciprocating pumps for refinery duties up to +260°C; sludge pumps and swivels.

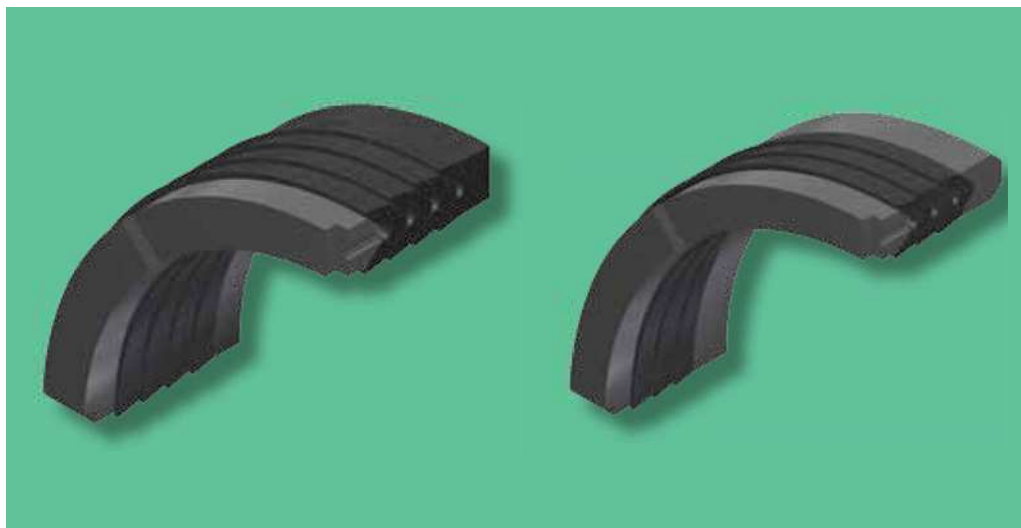

### Operating capabilities

- **Maximum operating pressure:** 42MPa (6092psi). *Modified design/materials can considerably extend this.*
- **Temperature range** (standard materials): -20°C to +100°C (-4°F to +212°F) for up to 250mm (9.84 in) OD, or to +120°C (+248°F) above 250mm (9.84 in) OD.
- **Maximum temperature** (special materials): up to +260°C (+500°F).
- **Maximum surface speed:** 0.5m/s (98.4fpm). *For higher speeds please consult our Technical Support Team.*

### Materials of construction

Size range	Set ring	Standard materials	Special materials
Up to & including 250mm OD (9.84 in)	Gland (female adapter)	High performance acetal copolymer	A range of solid rubbers.  Fabric proofed with hydrogenated nitrile (HNBR) or fluorocarbon (FKM) and others.
	V-shaped intermediate	Cotton fabric proofed with a blend of synthetic rubbers	
	*Header (male adapter)	High performance acetal copolymer	
Above 250mm OD (9.84 in)	Gland (female adapter)	Cotton fabric proofed with a blend of synthetic rubbers	Acetal, PEEK™, PTFE UHMWPE, nylon, etc.  A range of metals.
	V-shaped intermediate	Cotton fabric proofed with a blend of synthetic rubbers	
	*Header (male adapter)	Solid hard rubber, or cotton fabric proofed with a blend of synthetic rubbers	

#### \* Non-standard — spring-loaded headers

Header rings produced from thermoplastics or metals in radial sections of 6.5mm (0.256 in) and above can be supplied with multiple open-coil springs to give a degree of compensation for wear and loss of interference of sealing rings.

## Chevron® for rods/glands &amp; pistons

**Media capabilities**

**Standard materials** are suitable for use with most mineral-based hydraulic fluids, and most fire-resistant fluids of the water/oil or water/glycol types at up to 100°C (212°F). Also resistant to air, water and most lubricating oils and greases.

Where fire-resistant fluids are used, it is essential to advise our Technical Support Team of the type and designation due to the effects that can occur with different grades.

**Special materials** considerably extend the range of application in terms of temperature, fluid compatibility and abrasion resistance. Ask our Technical Support Team for further information.

**How supplied**

(Also see *Hydraulic sealing products — Size charts*, which can be downloaded from [www.jameswalker.biz](http://www.jameswalker.biz))

Available in radial sections from 4mm (0.16 in) upwards; spring-loaded versions from 6.5mm (0.26 in). Endless rings available up to 2.2m (87 in) OD.

Endless packing sets in standard materials to suit housings to BS ISO 5597 — Long (L3) axial length series are readily available. Inch sizes and split packing sets are also available.

Fitting instructions are supplied with every packing set.

**Chevron® typical housings**

See Appendix A (page 54) for preferred housing designs, and Appendix W (pages 79-82) for BS ISO 5597 — Long (L3) axial length series housings.

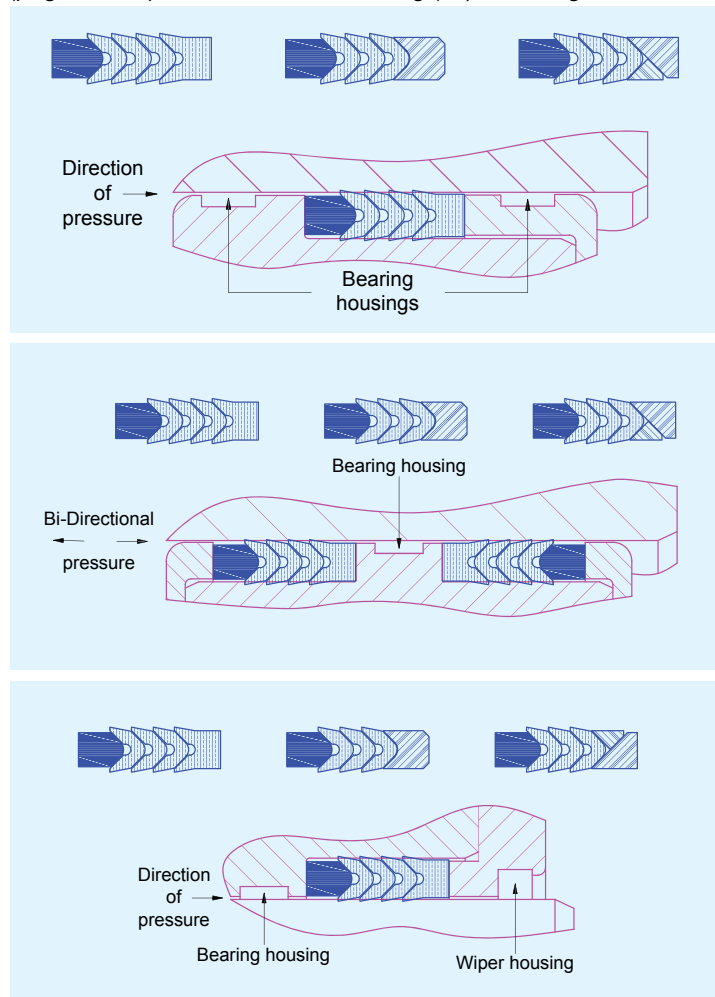

**Chevron®  
single-acting  
piston application**

**Chevron®  
double-acting  
piston application**

**Chevron® rod  
application**

# Solosele® G seal for rods/glands & pistons

## Solosele® G

*Robust single element seal*

### Description

**Solosele® G is our compact rod/gland seal and single-acting piston seal that saves space without compromising its high integrity sealing capabilities.**

Standard versions comprise a profiled elastomeric sealing element that is firmly protected by an integral anti-extrusion element of rubber-proofed fabric. High integrity sealing is enhanced by its flexible chamfered lips.

In operation, the elastomeric element provides low-pressure sealing by means of radial squeeze. As pressure increases, its pressure responsive action maintains the sealing force — even when there is significant rod misalignment.

The tough integral fabric/rubber base resists extrusion whilst being sufficiently flexible to allow recess fitting in the majority of cases.

### Special features

- Compact seal with excellent high and low pressure sealing capabilities.
- Excellent extrusion resistance for long operational life.
- Simple to fit.
- Cost savings through simple housing groove requirements.

### Special versions

**Solosele® G-AE** is available with separate triangular base ring (internal or external) of PTFE, nylon or acetal to reduce friction or limit seal contact area on short stroke applications. Dependent on whether the seal is used in a rod/gland or piston sealing application, the seal base ID or OD corner has a moulded chamfer recess in which the split anti-extrusion (AE) element/ring is positioned.

**Odd-legged** design is available to prevent excessive axial movement within the housing. This prevents fluid pumping under the seal lip during low-pressure rod retraction.

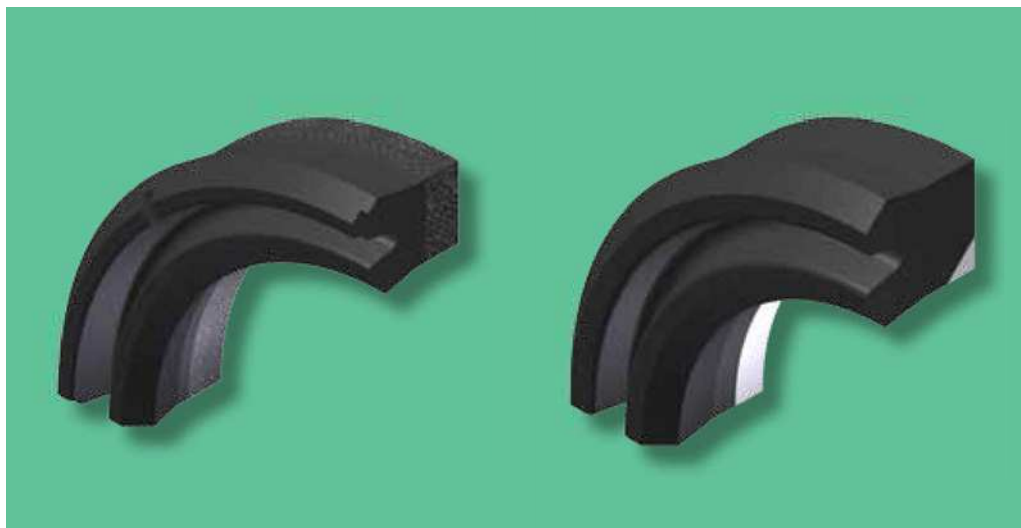

### Typical applications

Rod seal for hydraulic cylinders; ram seal for hydraulic presses; or single-acting piston seal. (Two seals can be used for double-acting piston duties, but care must be taken to relieve any potential inter-seal pressure build up.)

It is also suitable for slow semi-rotary applications including swivels and distributors. Additional duties include turbine blade roots, guide vanes and servo motors on hydroelectric plant — and as a static seal that offers the benefits of an 'O' ring with integral anti-extrusion capability.

### Operating capabilities

- **Maximum operating pressure:** 42MPa (6092psi).
- **Temperature range** (standard materials): -20°C to +120°C (-4°F to +248°F).
- **Temperature limits** (special materials): down to -45°C (-49°F) with low nitrile (NBR); or up to +200°C (+392°F) with fluoroelastomer (FKM).
- **Maximum surface speed** (reciprocating): 0.5m/s (98.4fpm).  
*For higher speeds please consult our Technical Support Team.*

### Materials of construction

#### Elastomeric sealing element

*Standard material:* medium nitrile (NBR).  
*Special materials:* low nitrile (NBR), or fluoroelastomer (FKM).

#### Anti-extrusion element

*Standard material:* cotton fabric proofed with a blend of synthetic rubbers.  
*Special materials:* cotton fabric proofed with blend of synthetic rubbers for use with sealing element of low nitrile (NBR). Fabric proofed with fluorocarbon (FKM) for use with sealing element of fluorocarbon (FKM).

### Media capabilities

**Standard materials** are suitable for use with most mineral based hydraulic fluids, and most fire-resistant fluids of the water/oil emulsion or water/glycol types at temperatures up to 120°C (248°F). They also resist air, water, and most lubricating oils and greases.

**Special materials** extend considerably the range of application in terms of temperature, fluid compatibility and abrasion resistance. Please consult our Technical Support Team.

# Solosele® G seal for rods/glands & pistons



## Solosele® G typical housings

See Appendix B (page 55) for preferred housing designs and Appendix W (pages 79-82) for BS ISO 5597 — Short (L1) and Medium (L2) axial length series, and BS ISO 6020-2 housings.

### Single-acting piston applications

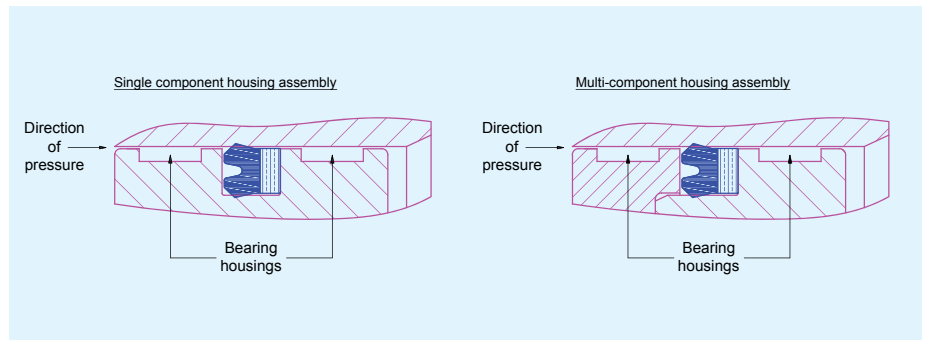

### Double-acting piston applications

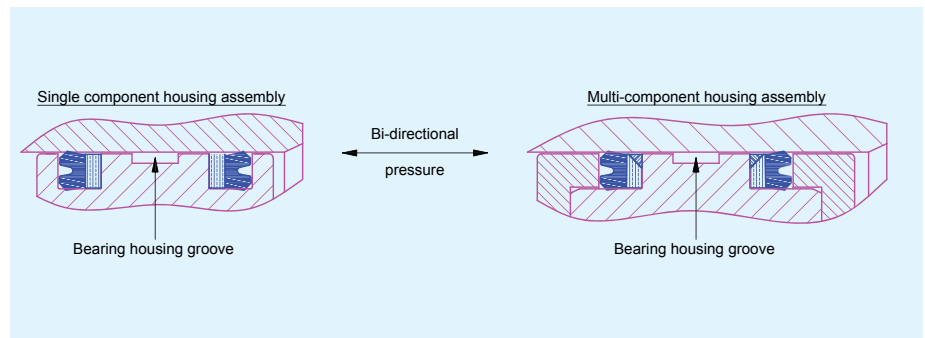

### Shaft sealing applications

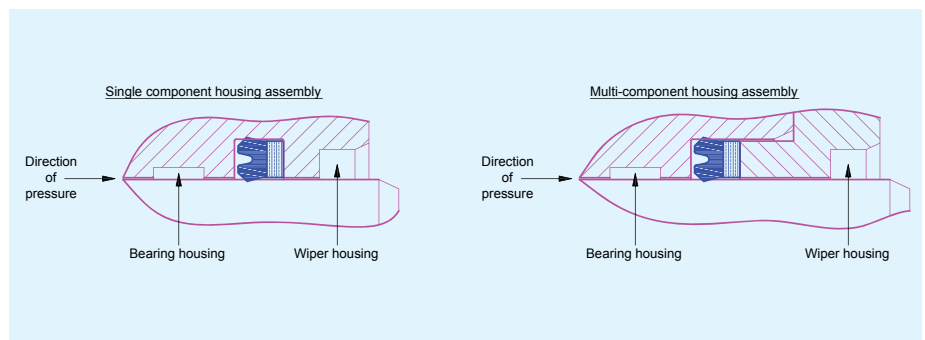

### Typical Solosele® G constructions

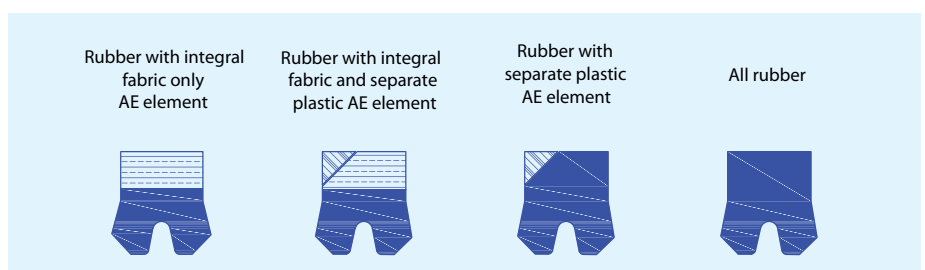

### How supplied

(Also see Hydraulic sealing products — Size charts, which can be downloaded from [www.jameswalker.biz](http://www.jameswalker.biz))

Standard sizes to fit piston head and rod/gland housings to BS ISO 5597 — Short (L1) and Medium (L2) axial length series, and BS ISO 6020-2 are readily available. Numerous other moulds available for non-standard sizes from 3mm ID to 2.2m OD. Standard inch sizes from 0.125 inch ID to 87 inch OD.

Other sizes within these metric and inch limits are manufactured to order, but tooling charges may be incurred.

Larger diameter endless seals — to unlimited OD — can be made using our special mould-joining technique.

Solosele® G is supplied as standard in endless form for optimum sealing performance.

Fitting instructions are supplied with every seal.

# Twinset packing for rods/glands & pistons

## Twinset

*Well proven over many decades*

### Description

**Twinset is our pressure responsive packing set that boasts a record of success stretching back over 50 years. Although we recommend our more advanced designs for many of the traditional Twinset applications, this product remains a firm favourite with the operators of older hydraulic plant.**

The packing set comprises an endless U-ring firmly supported by a header ring. The lips of the U-ring are slightly flared to provide an interference fit for initial sealing. When system pressure is applied, the sealing force is increased significantly by reaction within the tongue-shaped cavity of the U-ring.

Under slight axial compression, the header ring also spreads the U-ring lips slightly to improve low pressure sealing efficiency.

### Special features

- Very well proven on reciprocating plant worldwide.
- Readily available in traditional sizes for older plant.
- Suitable for adjustable and non-adjustable axial length housings.

### Typical applications

Twinset was developed for use on vertically reciprocating hydraulic shafts and rams. Current applications include the main rams of upstroking/gravity return presses and downstroking/prefilling type presses. Twinset has also proved successful on press drawback rams, hydraulic piston heads, jacks and hoists, and hydraulic valves.

This packing set should not be used under abrasive conditions or for heavy-duty applications (eg, forging or extrusion presses), or on rams subjected to shock loads or side loads. In these cases, please ask our Technical Support Team to recommend a suitable product.



### Operating capabilities

- **Maximum operating pressure:** 34MPa (4931psi).
- **Maximum temperature** (standard materials): 100°C (212°F).
- **Maximum surface speed:** 0.5m/s (98.4fpm).

### Materials of construction

#### U-ring

*Standard material:* cotton fabric proofed with a blend of synthetic rubbers.

#### Header ring

*Standard material:* nylon, or a similarly hard composite.

*Spring-loaded:* header rings of 6.5mm section and above can be supplied with multiple coil springs for the automatic compensation of wear when used in non-adjustable housings.

### Media compatibility

Standard materials are suitable for use with most mineral based hydraulic fluids, lubricating oils and greases at temperatures up to 100°C (212°F). They are also resistant to water and air.

The standard materials prove satisfactory for use with a number of fire-resistant fluids, including many of the phosphate ester type. Although swell will occur, most users find that this does not impair plant performance. *Where fire-resistant fluids are used, it is essential to advise our Technical Support Team of the type and designation.*

### How supplied

*(Also see Hydraulic sealing products — Size charts, which can be downloaded from [www.jameswalker.biz](http://www.jameswalker.biz))*

Endless rings only, up to 1675mm (66 in) OD, with sections from 5mm (0.19 in) upwards. Please state whether housings are adjustable or non-adjustable.

All standard sizes shown in our charts are supplied without tooling charges. For sizes above 1675mm (66 in) OD, please consult our Technical Support Team.

Fitting instructions are supplied with every seal.

# Twinset packing for rods/glands & pistons

## Twinset typical housings

See Appendix C (page 56) for preferred housing designs.

### Piston sealing — single acting

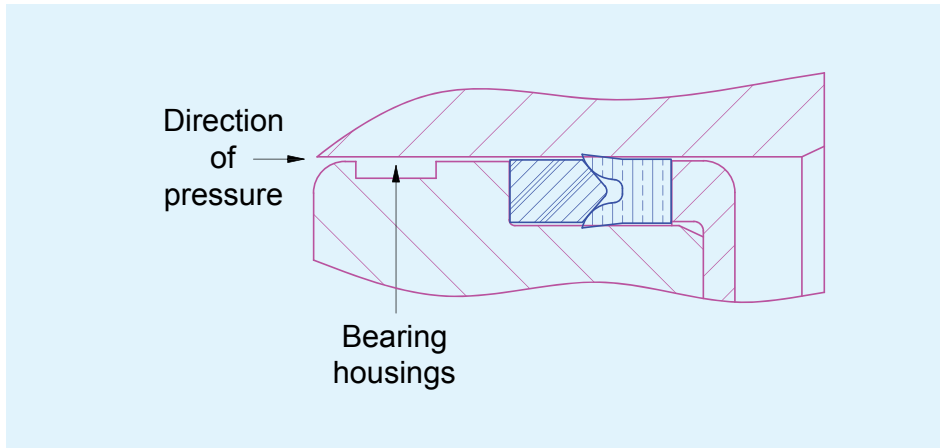

### Piston sealing — double acting

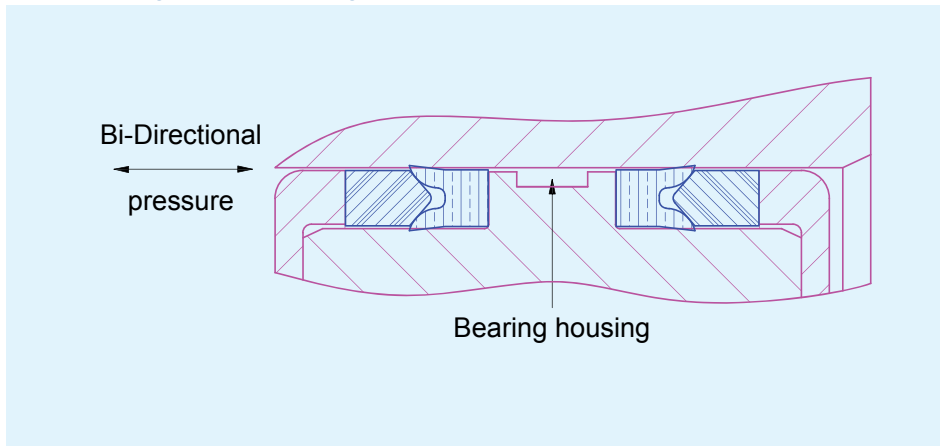

### Shaft sealing

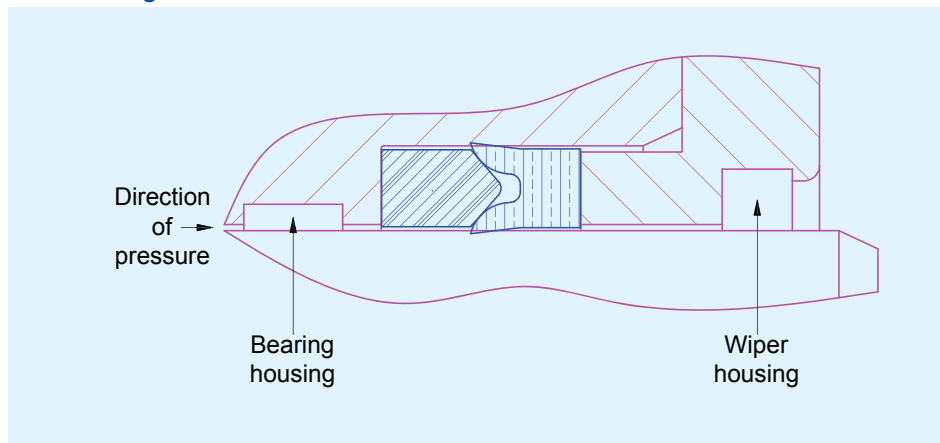

# Lionsele® LF for rods/glands & pistons

## Lionsele® LF

*High performance, low friction*

### Description

**This compact seal is the high performance answer to fluid sealing in extreme operating conditions of temperature, speed and chemical media.**

The seal comprises a PTFE U-ring energised by a highly developed finger spring. This arrangement provides ample resilience to keep the lips in sealing contact with their mating surfaces at low pressure, whilst the pressure-responsive seal profile ensures excellent sealing performance at high pressures.

Lionsele® LF is suitable for reciprocating, static and some rotary applications.

### Special features

- Very low friction for smoothest operation.
- Seize-free action after long periods in static mode.
- Excellent performance at high and low pressures.
- Special spring design gives an evenly distributed load across large deflections.
- Fits 'O' ring housings.
- Wide temperature range and almost universal media compatibility enable this seal to work in the most aggressive environments.

### Typical applications

Lionsele LF is recommended as a high-performance replacement for elastomeric or polymeric lip seals and 'O' rings working in extreme conditions, typically in hydraulic and pneumatic systems, oil and gas valves, defence and aerospace, cryogenic, automotive, medical equipment, and general industrial applications.

### Operating capabilities

- **Maximum operating pressure:**  
Dynamic duties: 35MPa (5076psi)  
Static duties: 40MPa (5802psi).
- **Temperature range:**  
Virgin PTFE: -250°C to +260°C  
(-418°F to +500°F).  
PTFE/aromatic polyester: -130°C to +300°C (-202°F to +572°F).
- **Maximum surface speed:**  
5m/s (984fpm).



### Materials of construction

#### Body

Fluolion® (virgin PTFE); Fluolion GR with 25% carbon/graphite; Fluolion B60 with 60% bronze; or Fluolion with 10% aromatic polyester.

Each Fluolion grade has specific frictional, wear and chemical resistant qualities. Please consult our Technical Support Team regarding your optimal material.

#### Finger spring

Stainless steel as standard, with cobalt/chrome alloy available.

Stainless steel is recommended for the majority of applications. The cobalt/chrome is NACE-approved and resists stress cracking in sour H<sub>2</sub>S environments.

### Media capabilities

The almost universal compatibility of PTFE ensures that Lionsele LF is suitable for use with all commonly found hydraulic fluids, steam, water and corrosive media. Spring materials may need to be selected to meet precise operational parameters.

### Operational considerations

#### Shaft hardness

For optimum operational life, particularly at higher pressures, we recommend a minimum shaft hardness of:

- 300 Brinell (31 Rockwell C) for dynamic.
- 220 Brinell (19 Rockwell C) for static.

### How supplied

(Also see *Hydraulic sealing products — Size charts*, which can be downloaded from [www.jameswalker.biz](http://www.jameswalker.biz))

To fit 'O' ring housing grooves for SAE AS586 (inch) and BS ISO 3601-2 (metric) sizes, where BS ISO 3601 supersedes BS1806. Also manufactured to suit customers' specific equipment.



# Lionsele® LF for rods/glands & pistons

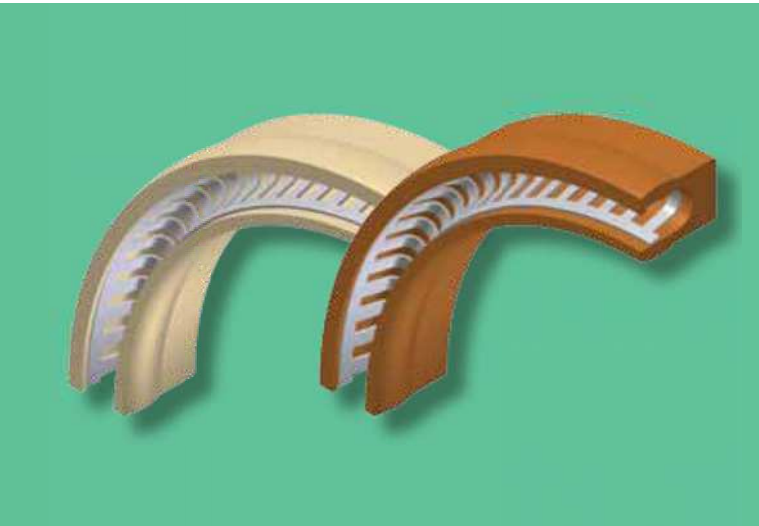

## Housing type recommendations

### Split housing

We recommend a split housing for high-integrity sealing and cryogenic applications. Where a split housing is impractical, we suggest the following methods.

### Non-split cylinder housing

Use this method only when the outside diameter of Lionsele® LF is at least ten times its nominal section. This requires a 15° lead-in to the housing groove from the pressure side, with a locking lip of 0.25 times nominal radial section to ensure efficient sealing.

### Non-split piston housing (partially enclosed)

Use this method only when the outside diameter of Lionsele LF is at least 25 times its nominal section. This requires a 15° chamfer to the housing groove from the pressure side, with a locking lip of 0.25 times nominal radial section to ensure efficient sealing.

### Fully enclosed non-split shaft housing

When no chamfer leads directly into the housing groove, the seal must be stretched over the diameter of the shaft. This should be attempted only when the inside diameter of the seal is at least 30 times its nominal section.

## Piston sealing — double acting

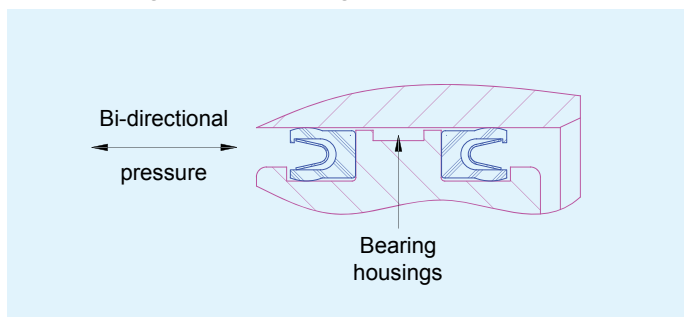

## Lionsele LF® typical housings

See Appendix D (page 57) for preferred housing designs.

### Shaft sealing

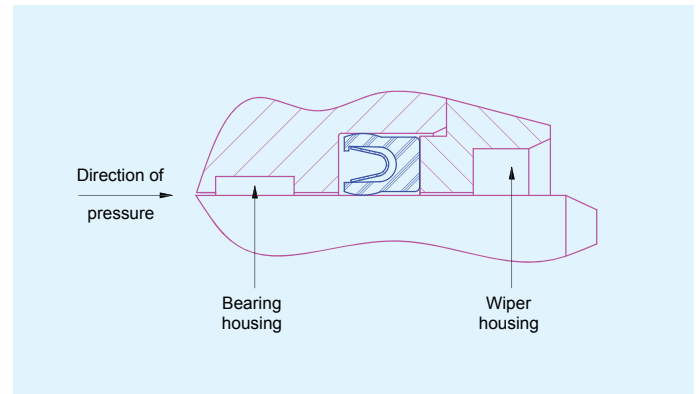

### Piston applications

#### Piston sealing — single acting

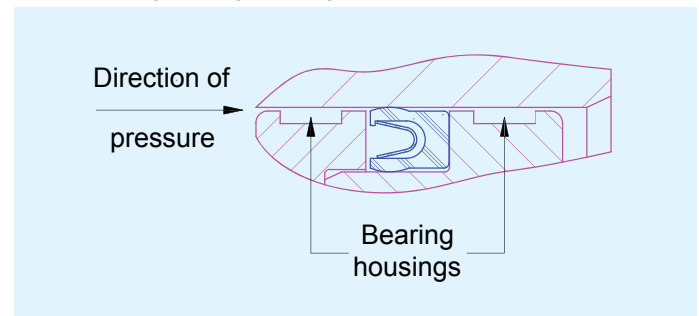

#### Piston sealing — double acting

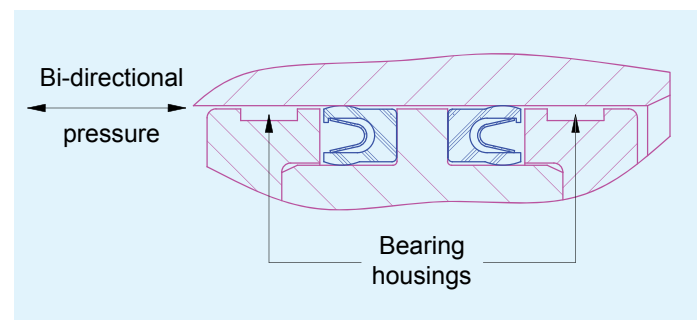

#### Piston sealing — double acting

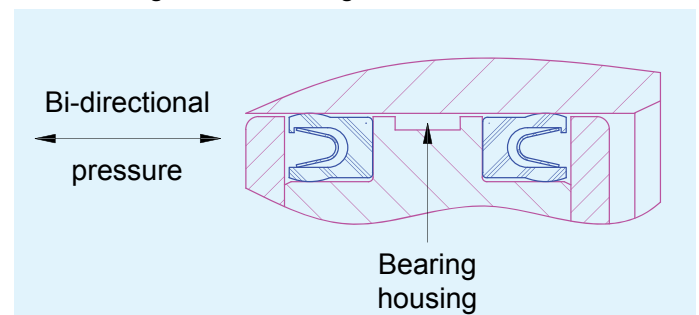

# Lionsele® U1 for rods/glands & pistons

## Lionsele® U1

For general duty hydraulics

### Description

**Lionsele® U1 is a U-profiled seal, of high-performance polyurethane, that provides excellent resistance to extrusion and abrasion in general duty hydraulic systems.**

The lip profile of this seal is designed as an interference fit within the housing. The radial squeeze provided by this action gives efficient sealing at low pressures. When pressure rises, the seal becomes pressure-responsive to maintain sealing forces throughout the operating range.

### Special features

- High mechanical strength polyurethane provides excellent resistance to wear and extrusion.
- Flexible lip ensures long and effective sealing life.
- Combination of seal material and design minimises plant downtime — even in aggressive working environments.

### Typical applications

General duty systems — rod seal for hydraulic cylinders, ram seal for hydraulic presses, and as single-acting piston seal.

### Operating capabilities

- **Maximum operating pressure:** 42MPa (6092psi).
- **Temperature range:** -30°C to +100°C (-22°F to +212°F).
- **Maximum surface speed:** 0.5m/s (98.4fpm).

### Materials of construction

Precision moulded in wear-resistant polyurethane (AU/EU).

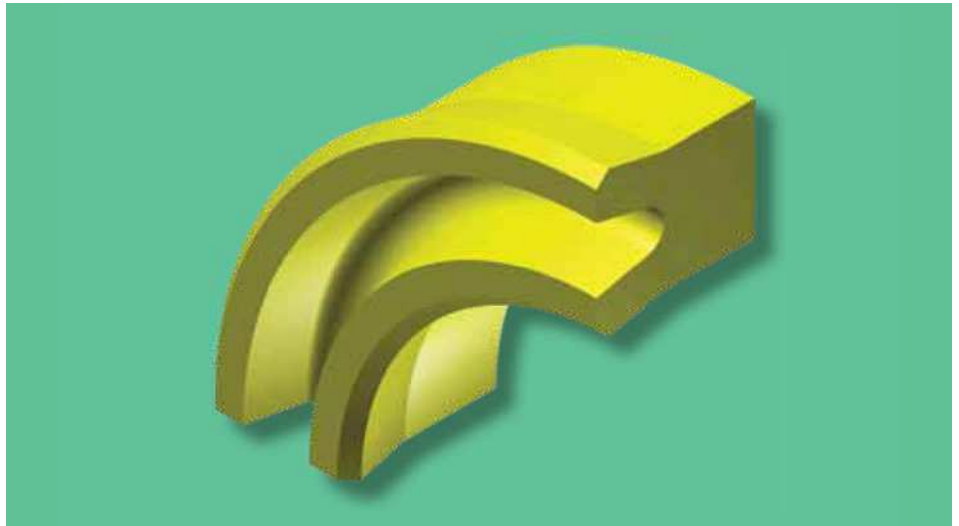

### Media capabilities

Suitable for use with most mineral-based hydraulic fluids at temperatures up to 100°C (212°F). Also resistant to air and most lubricating oils and greases. *Where fire-resistant fluids of the water/oil emulsion or water/glycol types are used, please contact our Technical Support Team for advice on temperature limits.*

### How supplied

(Also see Hydraulic sealing products — Size charts, which can be downloaded from [www.jameswalker.biz](http://www.jameswalker.biz))

To suit housings to BS ISO 5597— Short (L1) and Medium (L2) axial length series, and BS ISO 6020-2 housings. Other sizes can be manufactured to order.

Fitting instructions are supplied with every seal.

**Lionsele® U1 typical housings**  
See Appendix E (page 58) for preferred housing design, and Appendix W (pages 79-82) for BS ISO 5597— Short (L1) and Medium (L2) axial length series, and BS ISO 6020-2 housings.

### Piston sealing — single acting

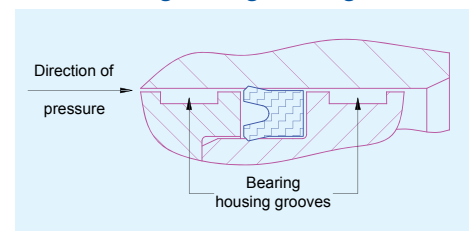

### Piston sealing — double acting

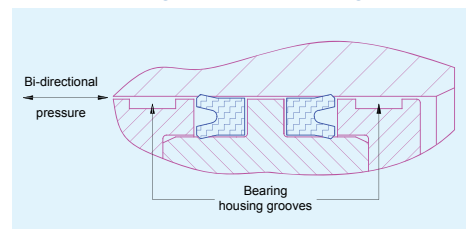

### Shaft sealing

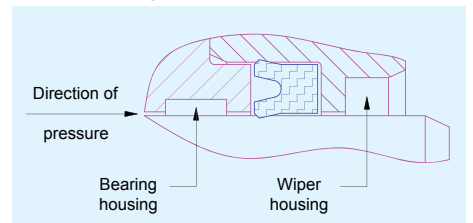

## U-ring seals for rods/glands &amp; pistons

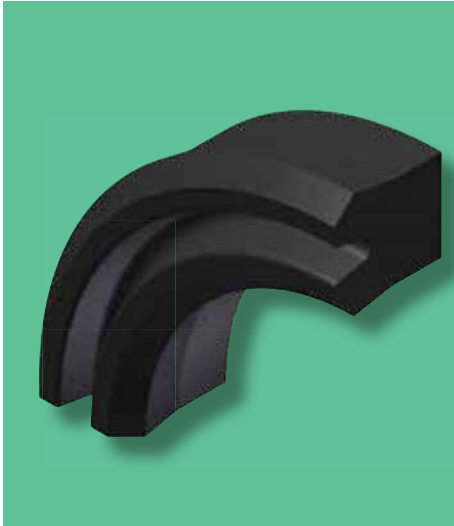

We supply a variety of U-rings to different designs — and in various materials including polyurethane — for hydraulic duties. The following are our most popular types.

#### Rubber construction

#### Fabric construction

Chamfered lip type

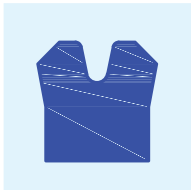

Square base type

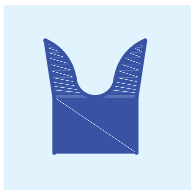

Round base type

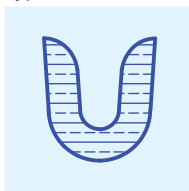
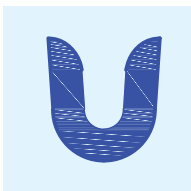

#### Rubber U-ring

*Suitable for stretch fitting*

##### Description

A family of moulded endless rubber U-ring seals, suitable for both rod and single acting piston applications. Available in a square or round base profile with moulded flared lips. Also, a square base profile with post moulded chamfered lips.

##### Operating capabilities

- **Maximum operating pressure:** 10MPa (1450psi).
- **Temperature range:** -20°C to +120°C (-4°F to +248°F).
- **Maximum surface speed:** 0.5m/s (98.4fpm).

##### Materials of construction

Manufactured as standard in 80 IRHD nitrile (NBR) elastomer. Other elastomer grades and hardnesses are available.

##### How supplied

Available in square-based or round-based profiles, and in a range of materials.

#### Fabric U-ring

*For more arduous duties*

##### Description

A family of moulded endless fabric U-ring seals, suitable for both rod and single acting piston applications. Available in a square or round base profile with moulded flared lips.

##### Operating capabilities

- **Maximum operating pressure:** 34MPa (4931psi).
- **Temperature range:** -20°C to +120°C (-4°F to +248°F).
- **Maximum surface speed:** 0.5m/s (98.4fpm).

##### Materials of construction

Manufactured as standard in nitrile (NBR) elastomer-proofed cotton fabric. Other materials are available.

##### How supplied

Available in square-based or round-based profiles and in a range of materials.

# Lofilm® multi-lip seal for rods/glands

## Lofilm®

Highly versatile multi-lip seal

### Description

As its name suggests, our Lofilm® rod and gland seal operates reliably for very long periods with the absolute minimum thickness of stable fluid film on the dynamic contact surface.

The seal comprises a robust gland ring/female adapter, plus one or more V-shaped intermediate rings, and a header ring. The header ring is a positive seal, precision moulded with a knife-cut sealing edge to give maximum integrity, and an annular groove to increase the response to applied pressure.

### Special features

- Highly versatile seal that reduces stockholding requirements.
- Excellent performance at high and low pressures.
- No axial compression — no in-service adjustments needed.
- Very low leakage rate reduces clean-up and top-up requirements.
- Available in split form for major downtime savings.
- Available with **Self-aligning Gland Ring** (see page 39) for use with heavily worn rams and other arduous duties.

### Typical applications

With its 'dry' running characteristics, Lofilm is the high performance seal most suitable for virtually all types of hydraulic press (main rams and drawback rams), hydraulic cylinder glands and single-acting piston heads, and hydraulic valves.



### Operating capabilities

- **Maximum operating pressure:** 42MPa (6092psi). *Modified design/materials can considerably extend this.*
- **Temperature range** (standard materials): -20°C to +100°C (-4°F to +212°F) up to 250mm (9.84 in) OD, or to +120°C (+248°F) above 250mm (9.84 in) OD.
- **Maximum temperature** (special materials): +200°C (+392°F).
- **Maximum surface speed:** 0.5m/s (98.4fpm). *For higher speeds please consult our Technical Support Team.*

### Materials of construction — up to & including 250mm (9.84 in) OD

#### Gland ring/female adapter

*Standard material:* high performance acetal copolymer.

*Special materials:* cotton fabric proofed with natural rubber (NR), hydrogenated nitrile (HNBR), butyl (IIR), or fluorocarbon (FKM).

#### Intermediate rings

*Standard material:* cotton fabric proofed with a blend of synthetic rubbers.

*Special materials:* cotton fabric proofed with natural rubber (NR), hydrogenated nitrile (HNBR), butyl (IIR), or fluorocarbon (FKM). Also solid rubber or PTFE.

#### Header ring

*Standard material:* abrasion resistant medium nitrile (NBR) rubber.

*Special materials:* ethylene propylene (EPM) or fluorocarbon (FKM) rubber for use with certain phosphate ester fluids.

### Materials of construction — above 250mm (9.84 in) OD

#### Gland ring/female adapter

*Standard material:* cotton fabric proofed with a blend of synthetic rubbers.

*Special materials:* cotton fabric proofed with natural rubber (NR), hydrogenated nitrile (HNBR), butyl (IIR), or fluorocarbon (FKM).

#### Intermediate rings

*Standard & Special materials:* as for sizes up to and including 250mm (9.84 in) OD.

#### Header ring

*Standard & Special materials:* as for sizes up to and including 250mm (9.84 in) OD.

### Media capabilities

**Standard materials** are suitable for use with most mineral-based hydraulic fluids, and most fire-resistant fluids of the water/oil or water/glycol types at temperatures up to 100°C (212°F). Also resistant to air, water and most lubricating oils and greases. *Where fire-resistant fluids are used, it is essential to advise our Technical Support Team of the type and designation due to the effects that can occur with different grades.*

**Special materials** considerably extend the range of application in terms of temperature, fluid compatibility and abrasion resistance. Please ask our Technical Support Team for further information.

## Lofilm® multi-lip seal for rods/glands

**How supplied**

(Also see *Hydraulic sealing products — Size charts*, which can be downloaded from [www.jameswalker.biz](http://www.jameswalker.biz))

Available in radial sections from 4mm (0.16 in) upwards. Endless packing sets in standard materials to suit housings to BS ISO 5597 — Long (L3) axial length series are readily available up to 2.2m (87 in) OD. Inch sizes and split packing sets are also available. Other sizes are manufactured to order, but tooling charges may be incurred.

Fitting instructions are supplied with every seal.

**Lofilm® typical housings**

See Appendix F (page 59) for preferred housing designs, and Appendix W (pages 79-82) for BS ISO 5597 — Long (L3) axial length series housings.

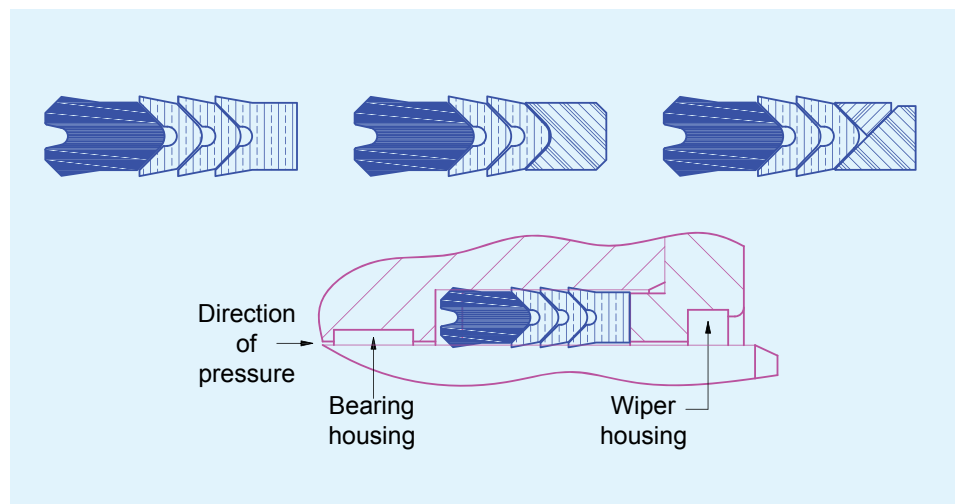

# Lion® Expanding Packing for rods/glands

## Lion® Expanding Packing *Traditional, robust multi-lip packing*

### Description

This heavy-duty packing set is highly proven on industry's most arduous applications. It has a sealing lip profile that is specially developed to withstand the massive side loads and high pressure peaks encountered on forging presses and other large metal-forming plant.

It provides efficient sealing on heavy-duty hydraulic systems and also gives 'bearing' support to the ram — which is particularly beneficial when the ram is horizontal. The 'bearing' role is a very successful feature that relies on the use of deep rings of robust construction to provide radial support to a large ram.

A Lion® Expanding Packing set comprises a heavy-duty gland ring/female adapter, two or more intermediate rings, and a header ring. All sealing rings have double lips. A V-shape base on the intermediate rings ensures that the packing responds automatically to system pressure and gives wedging action under gland compression — which helps to keep equipment in service, even with worn bushes or rams.

The sealing rings are moulded with an interference fit on the lips to give effective sealing at low pressure, which is augmented when system pressure is applied. The gland ring has a heavily reinforced base to resist extrusion; and individual rings are of very robust proportions to resist distortion under heavy side loads and high pressure peaks.

### Special features

- Robust multi-lip packing that withstands heavy side-loads and pressure peaks.
- Available in split form for major downtime savings.
- Tolerates aggressive working conditions to maintain plant efficiency.
- Extrusion resistant materials prevent seal damage in housing clearances.
- Available with **Self-aligning Gland Ring** (see page 39).

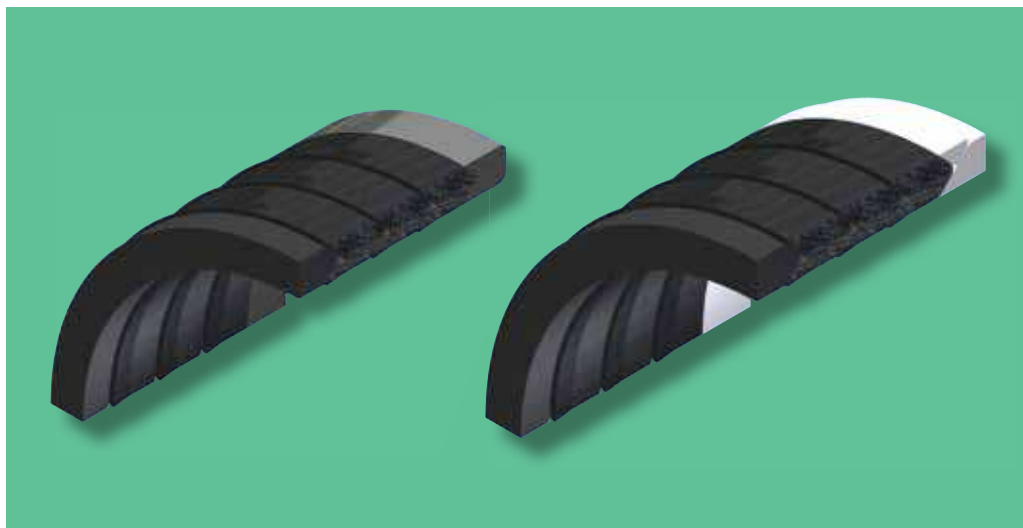

### Typical applications

Traditional heavy-duty ram seal for forging presses where high side-loads and pressure peaks are encountered. Also for horizontal extrusion presses where the sealing rings will help to provide radial support.

### Operating capabilities

- **Maximum operating pressure:** 62MPa (8992psi).
- **Temperature range** (standard materials): -20°C to +100°C (-4°F to +212°F).
- **Maximum surface speed:** 0.5m/s (98.4fpm). *For higher speeds please consult our Technical Support Team.*

### Materials of construction

#### Gland ring/female adapter

*Standard material:* heavy-duty cotton fabric proofed with medium nitrile NBR.

*Special materials:* heavy-duty synthetic fabric proofed with hydrogenated nitrile (HNBR), butyl (IIR) or fluorocarbon (FKM) rubber.

#### Intermediate rings

*Standard & Special materials:* as for gland ring.

#### Header ring

*Standard materials:* Type 1 — nitrile/styrene-butadiene blend of 100 IRHD; Type 2 — moulded or machined nylon; Type 3 — extruded nitrile of 90 IRHD.  
*Special materials:* acetal; glass-loaded PTFE; or nylon.

### Media capabilities

**Standard materials** are suitable for use with most mineral-based hydraulic fluids, and most fire-resistant fluids of the water/oil or water/glycol types at temperatures up to 100°C (212°F). Also resistant to air, water and most lubricating oils and greases.

**Special materials** considerably extend the range of application in terms of temperature, fluid compatibility and abrasion resistance. Please ask our Technical Support Team for further information.

### How supplied

(Also see *Hydraulic sealing products — Size charts*, which can be downloaded from [www.jameswalker.biz](http://www.jameswalker.biz))

Split packing sets to suit standard housing sections are available without tooling charges for ram diameters of 300mm to 1875mm, and 12 inch to 74 inch.

We have a substantial library of mould tools for split and endless sets. Other sizes are manufactured to order, but tooling charges may be incurred.

Fitting instructions are supplied with every seal.

# Lion® Expanding Packing for rods/glands



Lion® Expanding Packing — Recommended sections, diameters & depths

Shaft Ø e8 **		Radial depth (Section) S	Nominal set / housing depth		Chamfer length C Min
Above	Up to & including		Up to 35MPa	Above 35 and up to 62MPa	
Metric (mm)					
300.00	600.00	20.00	115.00	148.00	10.00
600.00	1200.00	25.00	145.00	183.00	
1200.00		30.00	175.00	224.00	12.50
Inch (in)					
12.000	18.000	0.750	4.500	5.500	0.375
18.000	24.000	0.875	5.000	6.375	
24.000		1.000	5.750	2.750	0.500

\*\* Tolerances in accordance with BS EN ISO 286-1 and BS EN ISO 286-2

## Lion® Expanding Packing typical housing arrangement

See Appendix G (page 60) for preferred housing designs.

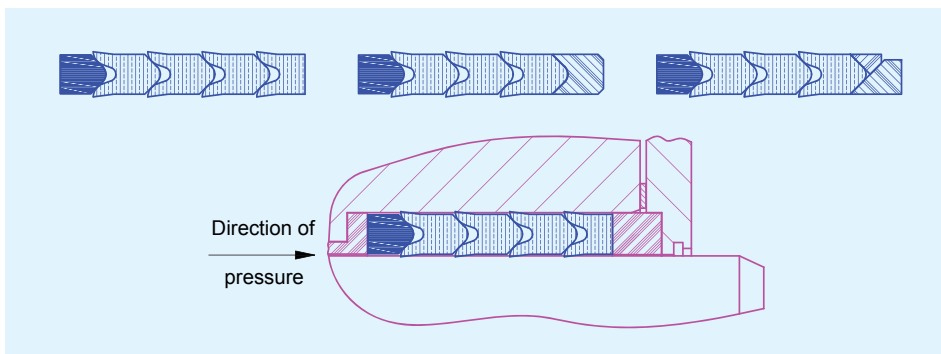

## Split packing sets

These are available to suit standard housing sections for the specific diameter ranges given in the following:

Axial length		Radial section	Outside diameter range	
L min	L max		Above	Up to & including
Metric sizes (mm)				
78.6	131.2	15.0	180.0	310.0
83.8	139.6	16.0	180.0	327.0
105.0	175.0	20.0	295.0	1935.0
131.4	219.3	25.0	520.0	1935.0
157.6	262.7	30.0	520.0	1935.0
Inch sizes				
3.30	5 1/2	5/8	7	13
3.92	6.545	3/4	12 1/8	30
4.587	7.672	7/8	12 3/8	76 1/8
5.173	8.631	1	20 1/2	76 1/8
6.408	10.479	1 1/4	20 1/2	76 1/8

# Lofilm® HD heavy-duty seal for rods/glands

## Lofilm® HD

Heavy-duty forging & extrusion presses

### Description

This pressure responsive seal is designed for arduous reciprocating gland applications — where fast pressure rises occur and side loads can be substantial. In heavy-duty horizontal applications, our Lofilm® HD operates as a highly efficient seal and also accommodates lateral or side loads.

The seal normally comprises one heavy-duty intermediate ring of rubberised fabric, a gland ring/female adapter, and a moulded rubber asymmetrical header ring as the principal sealing element of the set.

An annular groove incorporated in the header increases its response to applied pressure. The ported 'odd-leg' header design allows gland loading to be transferred through the set to the neck bush — often not fixed — while enabling the system pressure to act on the annular groove. In addition, the rubber sealing lips conform readily to an uneven surface, such as a worn shaft, to improve sealing integrity.

In operation, the initial radial interference reduces the fluid film to a minimum over a wide range of conditions, particularly on down-stroking where excessive leakage can be hazardous. This is also important on equipment that uses auxiliary cylinders to provide rapid action.

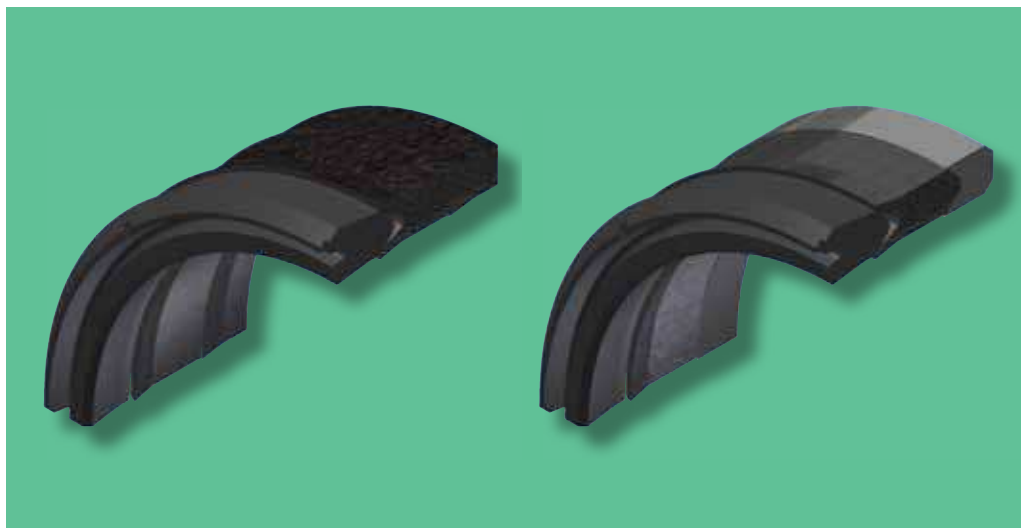

### Special features

- Robust high-integrity seal, well proven on heavy-duty ram applications.
- Pressure responsive primary sealing ring provides instant sealing action, even at low pressure.
- Improved sealing integrity on worn shafts to extend ram operating life.
- Available in split form for major downtime savings.
- Available with **Self-aligning Gland Ring** (see page 39).

### Typical applications

Arduous duties with rams on forging and extrusion presses, including heavy-duty horizontal applications. Also, equipment with rapid advance mechanisms, where Lofilm HD can prevent air being drawn into the system: this avoids uncontrollable movement of the main ram and possible severe damage to the seal and other components by cavitation.

### Operating capabilities

- **Maximum operating pressure:** 62MPa (8992psi).
- **Temperature range** (standard materials): -20°C to +120°C (-4°F to +248°F).
- **Maximum surface speed:** 0.5m/s (98.4fpm). For higher speeds please consult our Technical Support Team.

### Materials of construction

#### Gland ring/female adapter

**Standard material:** heavy duty cotton fabric proofed with medium nitrile (NBR) rubber.

**Special materials:** heavy duty synthetic fabric proofed with hydrogenated nitrile (HNBR), butyl (IIR), or fluorocarbon (FKM).

#### Intermediate ring

**Standard & Special materials:** as for gland ring.

#### Header ring

**Standard material:** nitrile (NBR) rubber.

**Special materials:** hydrogenated nitrile (HNBR), butyl (IIR), or fluorocarbon (FKM).

### Media capabilities

**Standard materials** (ie, nitrile NBR) are suitable for use with most mineral based hydraulic fluids, and most fire-resistant fluids of the water/oil emulsion or water/glycol types at temperatures up to 120°C (248°F). They also resist air, water, and most lubricating oils and greases.

**Special materials** extend considerably the range of application in terms of temperature, fluid compatibility and abrasion resistance. Please consult our Technical Support Team.



# Lofilm® HD heavy-duty seal for rods/glands



## Lofilm® HD typical housings

See Appendix H (page 61) for preferred housing designs.

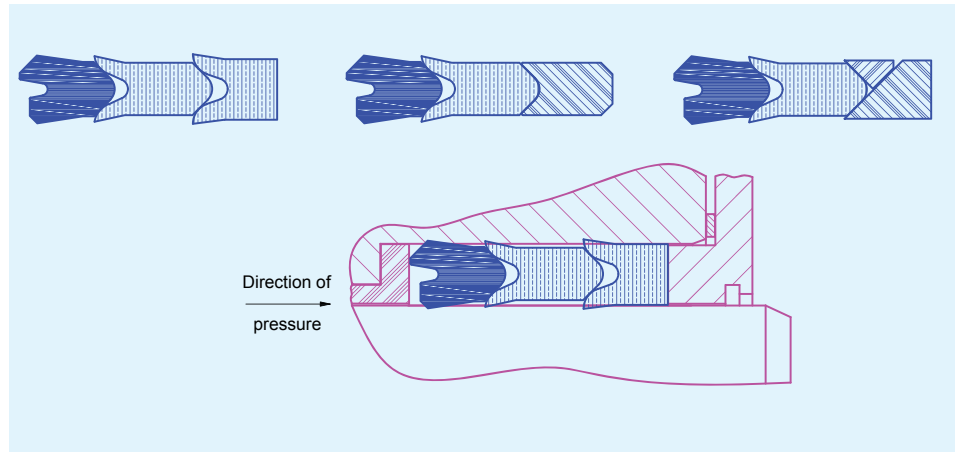

### How supplied

(Also see Hydraulic sealing products — Size charts, which can be downloaded from [www.jameswalker.biz](http://www.jameswalker.biz))

Endless or split packing sets to fit standard housings of 540mm to 1935mm OD, or 20½ inch to 76⅞ inch OD.

We also hold a substantial library of mould tools for non-standard sizes. Other sizes are manufactured to order, but tooling charges may be incurred.

Fitting instructions are supplied with every seal.

## Lofilm® HD recommended sections, diameters & depths

Shaft Ø e8 **		Radial depth (Section) S	Housing length L	Chamfer length C Min
Above	Up to & including			
Metric (mm)				
500.00	1000.00	25.00	112.50	10.00
1000.00		30.00	135.00	12.50
Inch (in)				
19.625	24.000	0.875	3.313	0.375
24.000		1.000	4.500	0.500

\*\* Tolerances in accordance with BS EN ISO 286-1 and BS EN ISO 286-2

# Lionsele® G compact seal for rods/glands

## Lionsele® G

*High performance single-acting seal*

### Description

This compact rod/gland seal provides optimum sealing performance combined with smooth operation and low levels of breakout and dynamic friction. These features are efficiently achieved by using a PTFE sleeve supported by a rectangular elastomeric energiser.

In operation, the rectangular energiser helps to keep leakage to a minimum by evenly supporting the PTFE sleeve, preventing it from twisting or rocking in the housing. Stable fluid film conditions and consistent low friction values are therefore maintained.

In addition, the profile of the PTFE sleeve is designed to control leakage by ensuring that the maximum possible amount of residual fluid film is recovered from the piston rod on the return stroke.

Due to the self-lubricating properties of the running face of the seal, and its single-acting profile, two seals may be fitted in tandem to provide optimum leakage control without the risk of inter-seal pressure trapping.

### Special features

- High performance single-acting seal providing low wear and maintenance.
- Low dynamic and breakout friction for instant response, smooth operation and reduced power consumption.
- Rectangular energiser stabilises sealing element during operation giving optimum fluid retention and seal life.
- Should be used in conjunction with **Lionsele® B1** or **B2** bearing strips (see pages 45-46) to eliminate metal-to-metal contact and other problems associated with offset shafts.

### Typical applications

Systems where instant response and low power consumption are important and leakage is unacceptable. Examples include: hydraulic cylinders, mobile hydraulics, injection moulding machines, and downstroking presses.



### Operating capabilities

- **Maximum operating pressure:** 40MPa (5802psi).
- **Temperature range** (standard materials): -25°C to +120°C (-13°F to +248°F).
- **Maximum surface speed:** 5.0m/s (984fpm). *For higher speeds please consult our Technical Support Team.*

### Materials of construction

#### Energiser

*Standard material:* medium nitrile (NBR) elastomer.

*Special materials:* other elastomers to suit operating conditions, including fluoroelastomer (FKM) for high temperature duties.

#### PTFE sleeve

*Standard material:* Fluolion® B60 bronze-loaded PTFE.

*Special materials:* alternative grades of Fluolion® PTFE to suit specific applications.

### Media capabilities

**Standard materials** are suitable for use with most mineral-based hydraulic fluids, and most fire-resistant fluids of the water/oil or water/glycol types at temperatures up to 120°C (248°F). Also resistant to air, water and most lubricating oils and greases. *Where fire-resistant fluids are used, it is essential to advise our Technical Support Team of the type and designation due to the effects that can occur with different grades.*

**Special materials** considerably extend the range of application in terms of temperature, fluid compatibility and abrasion resistance. Please ask our Technical Support Team for further information.

### How supplied

*(Also see Hydraulic sealing products — Size charts, which can be downloaded from [www.jameswalker.biz](http://www.jameswalker.biz))*

Available in standard materials and sizes to suit housings to BS ISO 7425-2. Other sizes manufactured to order.

Fitting instructions are supplied with every seal.

# Lionsele® G compact seal for rods/glands

## Lionsele® G typical housings

See Appendix I (page 62) for preferred housing designs to BS ISO 7425-2.

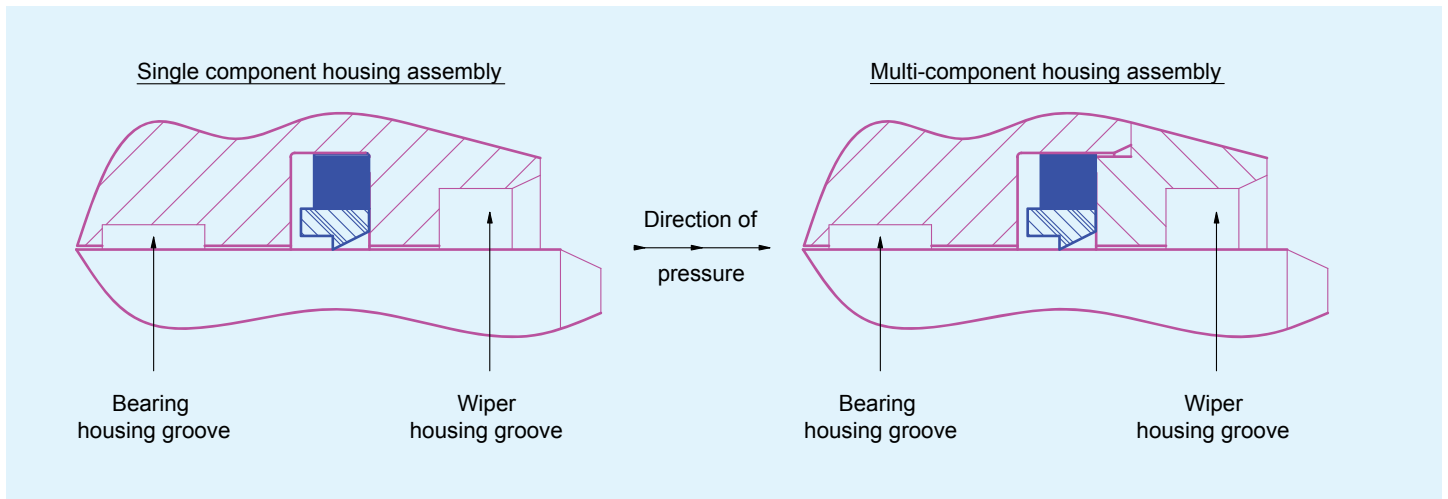

## Tandem housing arrangement

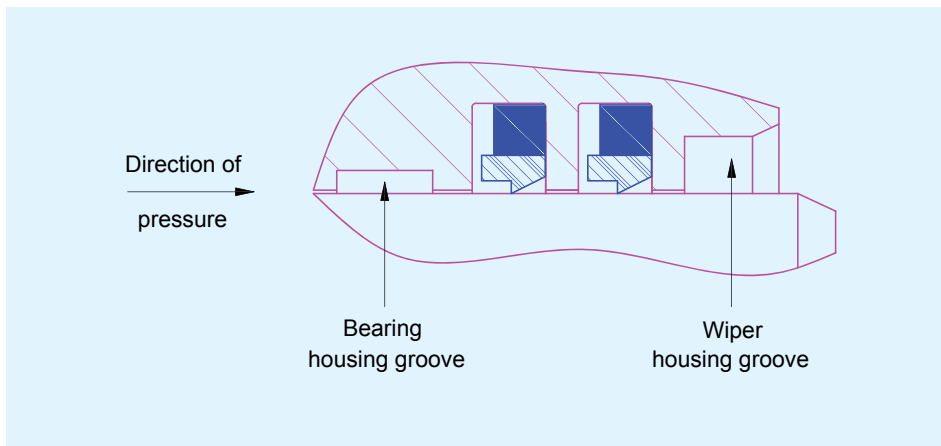

## Recommended sizes

Nominal rod diameter (mm / in)		Nominal radial width (mm / in)	Nominal groove length (mm / in)
Above	Up to and including		
-	14.90 / 0.59	2.50 / 0.10	2.20 / 0.09
14.90 / 0.59	24.90 / 0.98	3.75 / 0.15	3.20 / 0.13
24.90 / 0.98	59.90 / 2.36	5.50 / 0.22	4.20 / 0.17
59.90 / 2.36	199.90 / 7.87	7.75 / 0.31	6.30 / 0.25
199.90 / 7.87	-	10.50 / 0.41	8.10 / 0.32

# Lionsele® U2 for rods/glands

## Lionsele® U2

For general duty hydraulics

### Description

**Lionsele® U2 is a compact U-profiled rod/gland seal of high-performance polyurethane. Its asymmetrical design ensures sealing integrity when cylinder rod/ram deflections occur.**

In operation, the secondary sealing lip traps fluid behind the primary sealing lip and serves to increase lubrication. This prevents dry running, thus reducing the risk of stick-slip action. Seal life is significantly increased by the optimised fluid film conditions created beneath the primary sealing lip.

Moreover, the secondary sealing lip helps to exclude contamination from the primary sealing lip, further promoting seal life.

### Special features

- High mechanical strength polyurethane provides excellent wear resistance.
- Secondary seal lip optimises fluid film conditions to increase seal life and reduce plant downtime.
- Easy to fit.
- Low maintenance costs.

### Typical applications

Rod and ram seal for hydraulic cylinders on general duty systems, including mobile hydraulics, injection moulding machines and many other industrial applications.

### Operating capabilities

- **Maximum operating pressure:** 42MPa (6092psi).
- **Temperature range:** -30°C to +100°C (-22°F to +212°F).
- **Maximum surface speed:** 0.5m/s (98.4fpm).

### Materials of construction

Precision moulded in wear-resistant polyurethane (AU/EU).



### Media capabilities

Suitable for use with most mineral-based hydraulic fluids at temperatures up to 100°C (212°F). Also resistant to air, and most lubricating oils and greases. *Where fire-resistant fluids of the water/oil emulsion or water/glycol types are used, please contact our Technical Support Team for advice on temperature limits.*

### How supplied

(Also see Hydraulic sealing products — Size charts, which can be downloaded from [www.jameswalker.biz](http://www.jameswalker.biz))

To suit BS ISO 5597 — Short (L1) and Medium (L2) axial length series, and BS ISO 6020-2 housings. Other sizes can be manufactured to order.

Fitting instructions are supplied with every seal.

### Lionsele® U2 typical housings

See Appendix E (page 58) for preferred housing designs, and Appendix W (pages 79-82) for BS ISO 5597 — Short (L1) and Medium (L2) axial length series, and BS ISO 6020-2 housings.

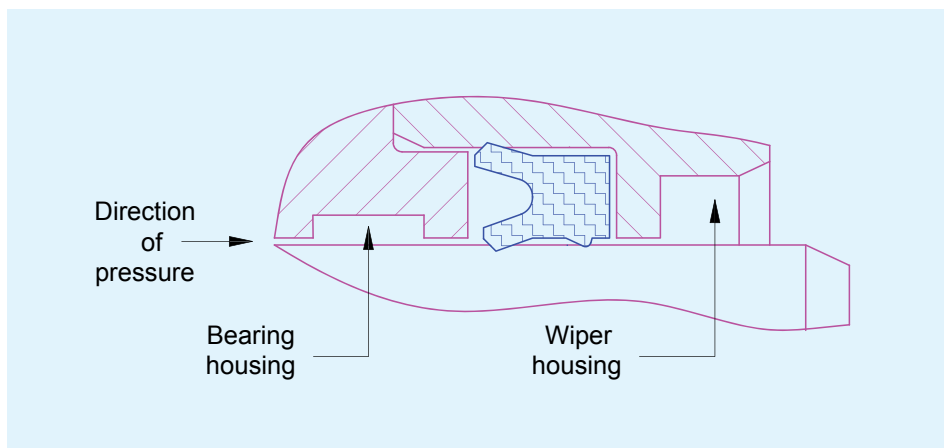

## Lionsele® SP for double-acting pistons

## Lionsele® SP

Double-acting seal for pistons

**Description**

**Lionsele® SP is a five-piece double acting seal with split anti-extrusion and wear rings, designed for use on spool type or single piece pistons. It is also suitable for use on two-piece piston assemblies.**

This seal comprises an elastomeric sealing element, two anti-extrusion rings, and two rigid thermoplastic wear/guide rings.

The elastomeric sealing element has an interference fit with the housing, to ensure sealing integrity, even at low pressures. The anti-extrusion rings prevent extrusion of the sealing element at higher pressures, whereas the wear/guide rings act as bearings to align the piston within the cylinder bore.

**Special features**

- Compact seal assembly that incorporates guide rings to minimise housing sizes.
- Robust seal with anti-extrusion elements that extend operating life and minimise plant downtime.
- Suitable for both one-piece and split-type pistons.

**Typical applications**

Double-acting cylinders on a wide range of industrial and mobile hydraulic systems.

**Operating capabilities**

- **Maximum operating pressure:** 42MPa (6092psi).
- **Temperature range:** -20°C to +100°C (-4°F to +212°F).
- **Maximum surface speed:** 0.5m/s (98.4fpm). *For higher speeds, please consult our Technical Support Team.*

**Materials of construction****Sealing element:**

'Medium' nitrile (NBR) elastomer.

**Anti-extrusion rings:**

High-performance polyurethane (AU/EU).

**Wear/guide rings:**

Polyacetal (POM).

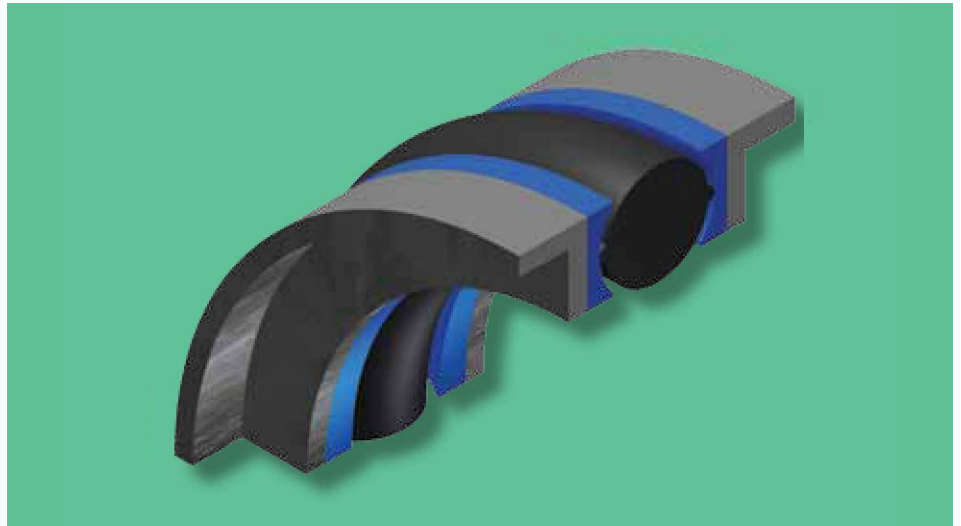
**Media capabilities**

Suitable for use with most mineral-based hydraulic fluids, and most fire-resistant fluids of the water/oil emulsion or water/glycol types, at temperatures up to 100°C (212°F). Also resistant to air, water and most lubricating oils and greases.

**How supplied**

(Also see *Hydraulic sealing products — Size charts*, which can be downloaded from [www.jameswalker.biz](http://www.jameswalker.biz))

To suit housings to BS ISO 6547. Other sizes can be manufactured to order.

Fitting instructions are supplied with each seal.

**Lionsele® SP typical housing**

See Appendix J (page 63) for preferred housing designs to BS ISO 6547.

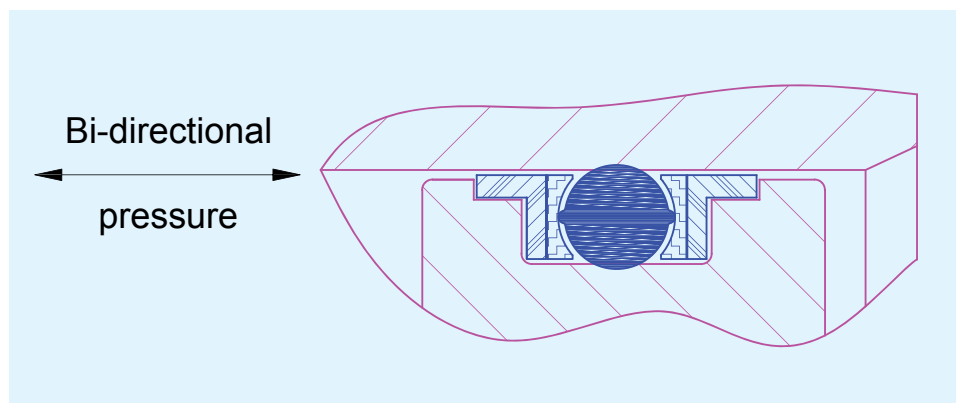

# Lionsele® P double-acting seal for pistons

## Lionsele® P

High performance double-acting composite seal

### Description

Our Lionsele® P is a compact, double-acting seal for piston heads. It has been developed to provide optimum sealing capability in conjunction with the lowest possible levels of dynamic and breakout friction.

The seal comprises a PTFE sleeve supported by a rectangular elastomeric energiser. The energiser distributes an even sealing load to the sleeve (unlike similar products that incorporate 'O' rings) to help minimise leakage.

In operation, the intimate face-to-face contact also prevents the sleeve twisting or rocking in the housing. This provides stable fluid film conditions with consistently low friction values.

The sleeve controls leakage by recovering the maximum possible amount of residual fluid film deposited on the cylinder bore. Its chamfered leading edges assist with the fluid film recovery, and also reduce the risk of seal damage through extrusion.

### Special features

- Compact design to suit simple recess grooves.
- Minimal wear.
- Low dynamic and breakout friction for smooth operation with reduced power consumption.
- Rectangular energiser stabilises the PTFE sealing element during operation to provide optimum fluid conditions and extended sealing life.
- Should be used in conjunction with **Lionsele® B1** or **B2** bearing strips (see pages 45-46) to eliminate metal-to-metal contact and other problems associated with offset pistons.



### Typical applications

Any duties where instant response and low power consumption are required. It is particularly recommended for high frequency/short stroke applications where there is a high risk of unstable fluid film conditions. Examples include: hydraulic cylinders, actuators, servomechanisms, machine tools, measuring instruments, gauge control equipment, and earth moving plant.

### Operating capabilities

- **Maximum operating pressure:** 40MPa (5802psi).
- **Temperature range** (standard materials): -25°C to +120°C (-13°F to +248°F).
- **Maximum surface speed:** 5.0m/s (984fpm). *For higher speeds please consult our Technical Support Team.*

### Materials of construction

#### PTFE sleeve

*Standard material:* Fluolion® CL — a filled PTFE material offering exceptional resistance to wear and abrasion.  
*Special materials:* alternative grades of Fluolion® PTFE to suit specific applications.

#### Energiser

*Standard material:* medium nitrile NBR elastomer.  
*Special materials:* other elastomers to suit operating conditions, including fluoroelastomer (FKM) for high temperature duties.

### Media capabilities

**Standard materials** are suitable for use with most mineral-based hydraulic fluids, and most fire-resistant fluids of the water/oil or water/glycol types at temperatures up to 120°C (248°F). Also resistant to air, water and most lubricating oils and greases. *Where fire-resistant fluids are used, it is essential to advise our Technical Support Team of the type and designation due to the effects that can occur with different grades.*

**Special materials** considerably extend the range of application in terms of temperature, fluid compatibility and abrasion resistance. Please ask our Technical Support Team for further information.

### How supplied

(Also see *Hydraulic sealing products — Size charts, which can be downloaded from [www.jameswalker.biz](http://www.jameswalker.biz)*)

Available in standard materials and sizes to suit housings to BS ISO 7425-1. Seals to other sizes or in special materials are manufactured to order.

Fitting instructions are supplied with every seal.

## Lionsele® P double-acting seal for pistons

## Lionsele® P typical housing

See Appendix K (pages 64-65) for preferred housing designs to BS ISO 7425-1.

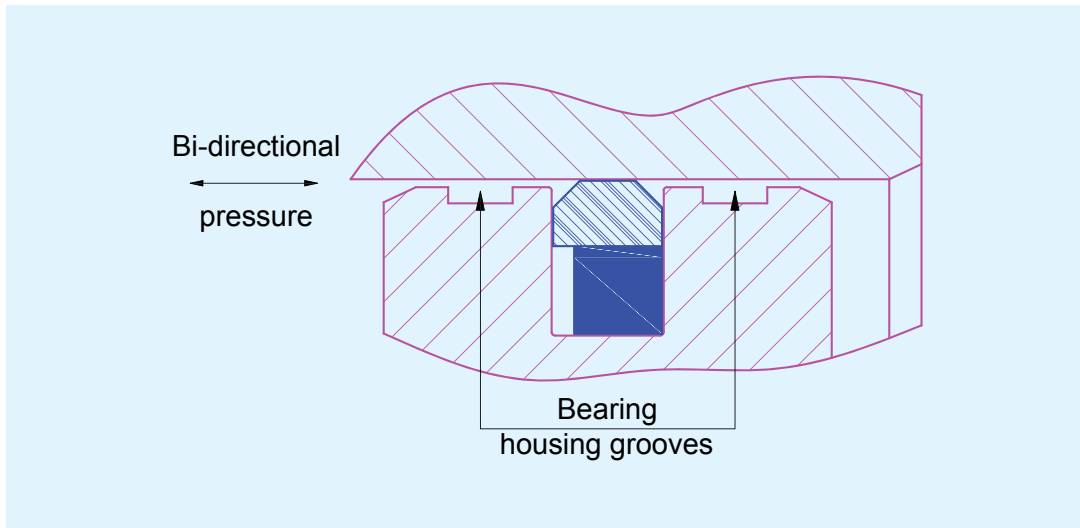

## Recommended sizes

Nominal cylinder diameter (mm/in)		Nominal radial width (mm/in)	Nominal groove length (mm/in)
Above	Up to and including		
-	39.90/1.57	3.75/0.15	3.20/0.13
39.90/1.57	79.90/3.15	5.50/0.22	4.20/0.17
79.90/3.15	132.90/5.23	7.75/0.31	6.30/0.25
132.90/5.23	329.9/12.99	10.50/0.41	8.10/0.32
329.9/12.99	669.9/26.37	12.25/0.48	8.10/0.32
669.9/26.37	999.9/39.37	14.00/0.55	9.50/0.37
999.9/39.37	-	19.00/0.75	13.80/0.54

# Solosele® S seal for pistons

## Solosele® S

*Designed for split-type piston heads*

### Description

**Solosele® S is our highly popular unit seal of simple construction, specially designed for use with double-acting split piston heads.**

Its durable construction comprises a solid elastomeric core, with integral elements of rubber-proofed cotton fabric on either side. The hard rubberised fabric acts primarily as an anti-extrusion element, but also fulfils an important role in wear reduction.

### Special features

- Robust double-acting seal.
- Compact unit that needs minimum housing space.
- Recommended for medium to heavy duty applications.
- Fully-moulded, one piece construction, with integral anti-extrusion elements for long life.
- Should be used in conjunction with **Lionsele® B1** or **B2** bearing strips (see pages 45-46) to eliminate metal-to-metal contact and other problems associated with offset pistons.

### Typical applications

Split piston heads in double-acting hydraulic applications of medium to heavy duty — especially where space is at a premium.

Operating capabilities

- **Maximum operating pressure:** 42MPa (6092psi).
- **Temperature range** (standard materials): -20°C to +120°C (-4°F to +248°F).
- **Temperature limits** (special materials): down to -45°C (-49°F) with low nitrile (NBR); or up to +200°C (+392°F) with fluoroelastomer (FKM).
- **Maximum surface speed:** 0.5m/s (98.4fpm). *For higher speeds please consult our Technical Support Team.*

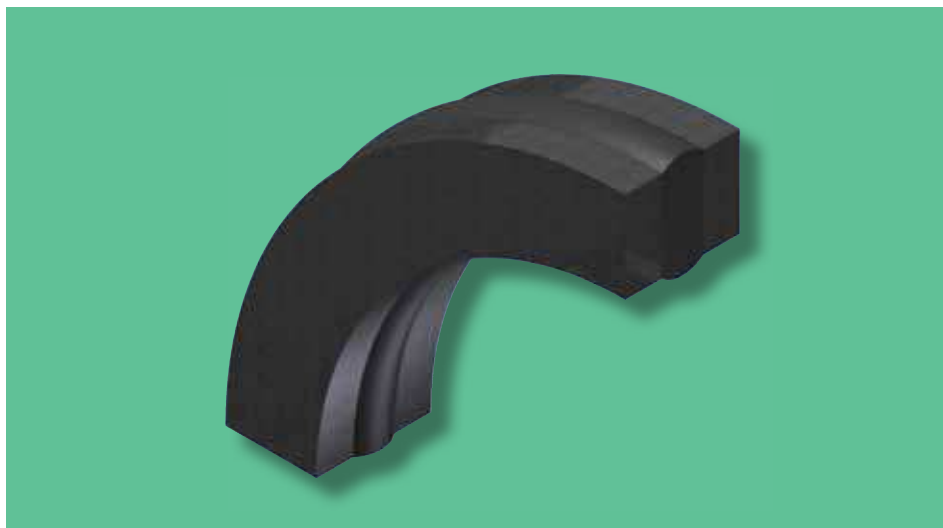

### Materials of construction

#### Elastomeric core

*Standard material:* medium nitrile (NBR).

*Special materials:* low nitrile (NBR), or fluorocarbon (FKM).

#### Anti-extrusion elements

*Standard material:* cotton fabric proofed with blend of synthetic rubbers.

*Special materials:* cotton fabric proofed with blend of synthetic rubbers for use with seal core of low nitrile (NBR). Fabric proofed with fluorocarbon (FKM) for use with seal core of fluorocarbon (FKM).

### Media capabilities

**Standard materials** are suitable for use with most mineral based hydraulic fluids, and most fire-resistant fluids of the water/oil emulsion or water/glycol types at temperatures up to 120°C (248°F). They also resist air, water, and most lubricating oils and greases.

**Special materials** extend considerably the range of application in terms of temperature and fluid compatibility. Please consult our Technical Support Team.

### How supplied

(Also see *Hydraulic sealing products — Size charts*, which can be downloaded from [www.jameswalker.biz](http://www.jameswalker.biz))

Readily available in standard materials to fit BS ISO 5597 — Medium (L2) axial length series housings. In addition, we hold a substantial library of mould tools for non-standard metric and inch sizes in our standard materials.

Seals of other non-standard sizes — or in special materials — are manufactured to order, but tooling charges may be incurred.

Fitting instructions are supplied with every seal.

### Solosele® S typical housing

See *Appendix L* (page 66) for preferred housing designs to BS ISO 5597 — Medium (L2) axial length series housings.

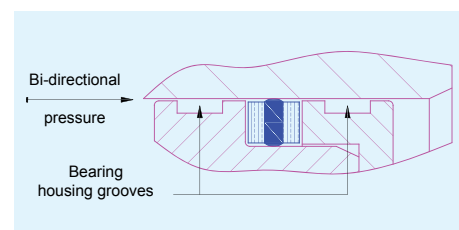



## Solosele® SW seal for pistons

## Solosele® SW

Robust double-acting piston seal

## Description

**Solosele® SW is designed primarily for medium to heavy duty applications. It is well proven on double-acting split pistons where larger clearances must be accommodated.**

The robust and durable construction of Solosele SW is based on a solid nitrile (NBR) elastomer core incorporating synthetic-rubber proofed cotton fabric elements on either side and thermoplastic bearings. The hard rubberised fabric acts as an anti-extrusion element whilst also reducing wear.

The L-section wear/bearing rings of thermoplastic are located at each end of the seal. These support the piston and prevent it making contact with the cylinder bore under side loads, obviating the need for bearing strips. They also reduce extrusion damage.

## Special features

- Robust double-acting seal for use on split-type piston heads.
- Recommended for medium to heavy duty applications.
- Fully moulded sealing element with integral anti-extrusion element to reduce seal wear and extend working life.
- Rigid thermoplastic wear/bearing rings allow for larger clearances and prolong seal life under side loads.
- Eliminates the need for bearing strips, thus reducing housing size.

## Typical applications

Split piston heads in double-acting hydraulic applications of medium to heavy duty. The compact design of this seal recommends it for applications where space is at a premium, especially under side loads and where clearances are large.

## Operating capabilities

- **Maximum operating pressure:** 42MPa (6092psi).
- **Temperature range** (standard materials): -20°C to +100°C (-4°F to +212°F).

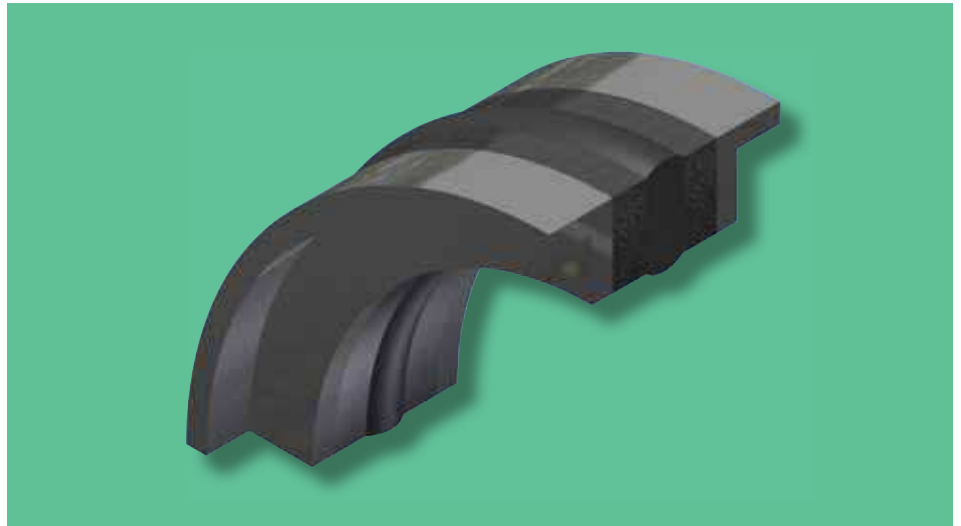

- Temperature limits (special materials): down to -45°C (-49°F) with low nitrile (NBR); or up to +200°C (+392°F) with fluoroelastomer (FKM).
- **Maximum surface speed:** 0.5m/s (98.4fpm). For higher speeds please consult our Technical Support Team.

## Materials of construction

## Elastomeric core

*Standard material:* medium nitrile (NBR).  
*Special materials:* low nitrile (NBR), or fluorocarbon (FKM).

## Anti-extrusion elements

*Standard material:* cotton fabric proofed with blend of synthetic rubbers.  
*Special materials:* cotton fabric proofed with blend of synthetic rubbers for use with seal core of low nitrile (NBR). Fabric proofed with fluorocarbon (FKM) for use with seal core of fluorocarbon (FKM).

## Wear/bearing rings

Polyacetal (POM).

## Media capabilities

**Standard materials** are suitable for use with most mineral based hydraulic fluids, and most fire-resistant fluids of the water/oil emulsion or water/glycol types at temperatures up to 100°C (212°F). They also resist air, water, and most lubricating oils and greases.

**Special materials** extend considerably the range of application in terms of temperature and fluid compatibility. Please consult our Technical Support Team.

## How supplied

(Also see Hydraulic sealing products — Size charts, which can be downloaded from [www.jameswalker.biz](http://www.jameswalker.biz))

Readily available in standard materials to fit popular housing sizes. In addition, we hold a substantial library of mould tools for non-standard metric and inch sizes in our standard materials.

Seals of other non-standard sizes — or in special materials — are manufactured to order, but tooling charges may be incurred.

Fitting instructions are supplied with every seal.

## Solosele® SW typical housing

See Appendix M (page 67) for preferred housing designs.

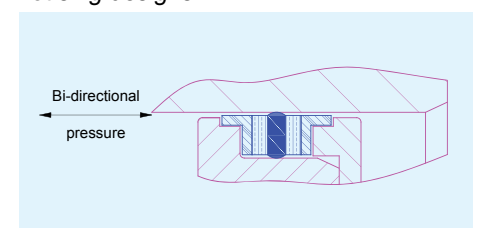

# Lionsele® U3 for pistons

## Lionsele® U3

Single-acting piston seal

### Description

**Lionsele® U3 is a U-profiled seal of high-performance polyurethane, designed for single-action use on hydraulic pistons. Two of these seals, installed in a back-to-back arrangement, can be used on double-acting pistons.**

The lip profile of this seal is designed as an interference fit within the housing. The radial squeeze provided by this action gives efficient sealing at low pressures. In operation, the seal becomes pressure-responsive to maintain sealing forces — even at very high pressures.

In addition, the asymmetric profile of the sealing lips reduces float of the seal in the housing. This improves efficiency and reduces the pumping of fluid under the sealing lip.

### Special features

- High mechanical strength polyurethane provides excellent extrusion and wear resistance to minimise plant downtime.
- Improved sealing performance across the operational pressure range reduces power losses in the hydraulic cylinder.

### Typical applications

Single-acting piston seal for hydraulic cylinders on general duty systems. For double-acting pistons, two separate seals can be used, but care must be taken to relieve any potential build up of internal pressure.

### Operating capabilities

- **Maximum operating pressure:** 42MPa (6092psi).
- **Temperature range:** -30°C to +100°C (-22°F to +212°F).
- **Maximum surface speed:** 0.5m/s (98.4fpm).

### Materials of construction

Precision moulded in wear-resistant polyurethane (AU/EU).



### Media capabilities

Suitable for use with most mineral-based hydraulic fluids at temperatures up to 100°C (212°F). Also resistant to air, and most lubricating oils and greases. *Where fire-resistant fluids of the water/oil emulsion or water/glycol types are used, please contact our Technical Support Team for advice on temperature limits.*

### How supplied

(Also see Hydraulic sealing products — Size charts, which can be downloaded from [www.jameswalker.biz](http://www.jameswalker.biz))

To suit BS ISO 5597 — Short (L1) and Medium (L2) axial length series, and BS ISO 6020-2 housings. Other sizes can be manufactured to order.

Fitting instructions are supplied with every seal.

### Lionsele® U3 typical housings

See Appendix E (page 58) for preferred housing designs, and Appendix W (pages 79-82) for BS ISO 5597 — Short (L1) and Medium (L2) axial length series, and BS ISO 6020-2 housings.

#### Single acting

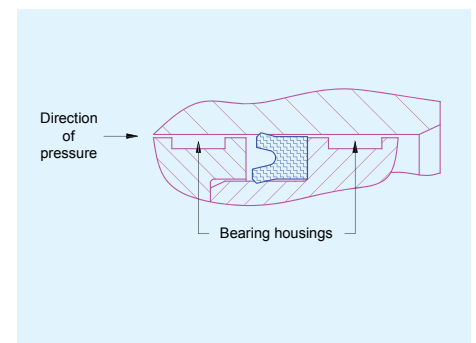

#### Double acting

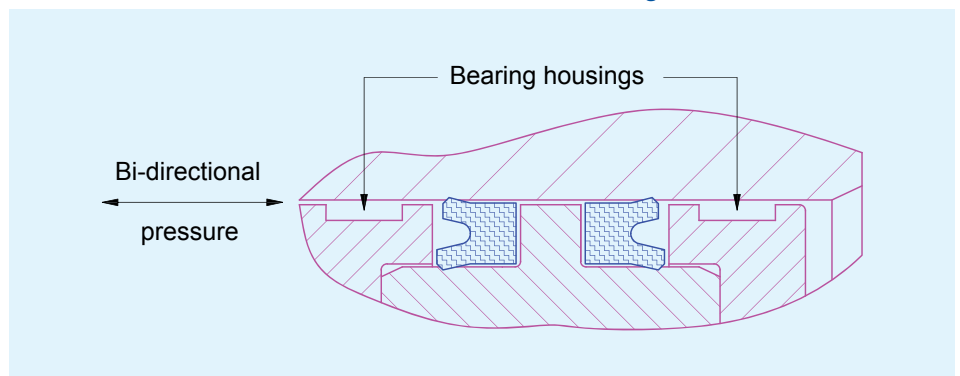

## Composite seals — special duty

### Composite seals

*Custom-designed for specific rod/gland or piston applications*

#### Description

In addition to our standard ranges of Lionsele® G and Lionsele® P, we regularly custom-design and manufacture hard-wearing compact composite seals to work to specific operational parameters with our customers' hydraulic and pneumatic plant. These can be piston or rod/gland seals.

Most of these seals comprise a sleeve of high-performance PTFE — such as our Fluolion® Xtreme — that is supported and energised by an elastomeric element.

The energiser is designed to distribute an even load to the PTFE sleeve, to maximise the sealing efficiency of the system and minimise leakage.

In operation, there is an intimate face-to-face contact for effective sealing, and the sleeve is securely restrained to prevent it rocking or twisting in its housing. This enables stable fluid film conditions to be maintained with consistently low friction values.

#### Special features

- Low dynamic and breakout friction for smooth operation with reduced power consumption.
- Compact designs to suit simple recess grooves.
- Elastomeric energiser stabilises the PTFE sealing element during operation to provide optimum fluid conditions and extended sealing life.
- Minimal wear.

#### Typical applications

Duties where instant response and low power consumption are required, and unstable fluid film conditions must be avoided. Examples include: actuators, servomechanisms, machine tools, measuring instruments, gauge control equipment, and construction plant.

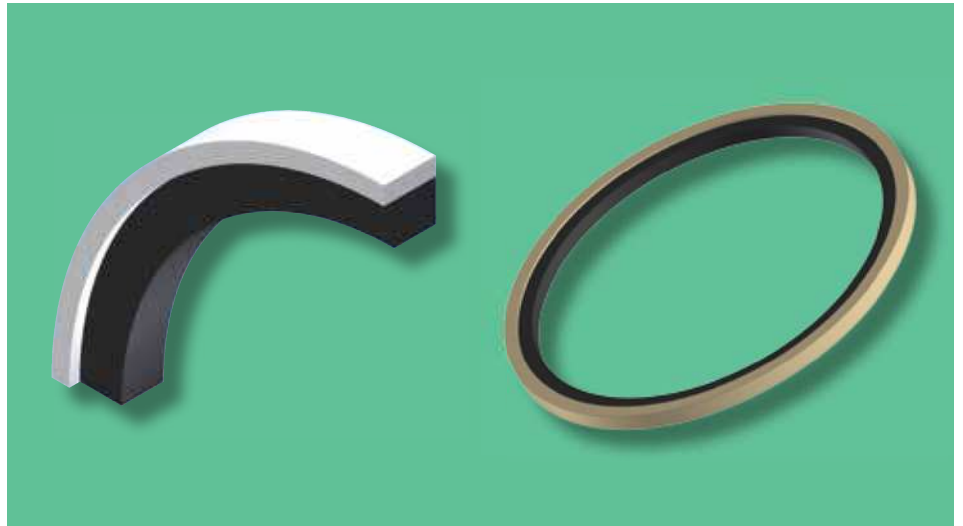

#### Typical operating capabilities

- **Maximum operating pressure:** 40MPa (5802psi).
- **Temperature range:** -25°C to +120°C (-13°F to +248°F), with highly extended temperature limits achievable using our specially formulated high performance elastomers.
- **Maximum surface speed:** 5.0m/s (984fpm).

#### Materials of construction

##### PTFE sleeve

Fluolion® virgin PTFE, Fluolion Xtreme or numerous other grades of filled Fluolion PTFE. Between them, these offer ranges of chemical compatibility, low-friction capability and wear/abrasion resistance to suit virtually any relevant hydraulic or pneumatic applications.

#### Energiser

We have a full complement of elastomer grades to suit specific operating conditions. These range from medium nitrile (NBR) for standard duties, to hydrogenated nitrile (HNBR), butyl (IIR), or fluoroelastomer (FKM) for high temperature operations.

#### How supplied

These seals are custom designed and manufactured to order to meet customers' specific operating parameters.

#### Composite seals typical housings

See Appendix N (page 68) for preferred housing designs.

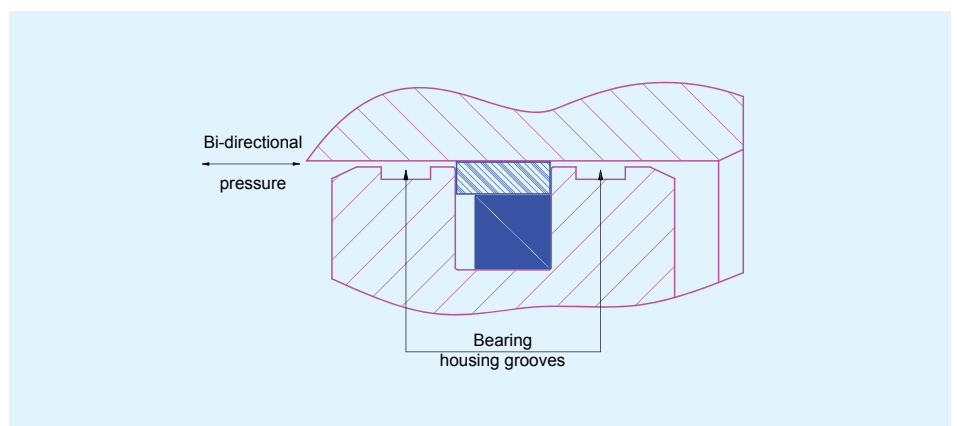

# Solosele® KB Hydro special duty seal

Solosele® KB Hydro  
For Kaplan turbine blade roots

## Description

**Solosele® KB Hydro is an innovative product developed specifically to seal the blade roots of Kaplan water turbines.**

This profiled elastomeric seal is reinforced at the base with an integral anti-extrusion element of rubber-proofed fabric that is securely mould-bonded to the lip portion. The anti-extrusion element is sufficiently tough to stop the seal from 'stretching and bunching' when the shaft rotates, yet is remarkably flexible for ease of fitting.

The very short axial length of this seal saves valuable housing space in new equipment. On older equipment with deeper housings, spacer rings can be supplied to move the sealing elements to unworn areas of the shaft.

## Special features

- Proves very cost effective.
- Excellent sealing capability under fluctuating conditions.
- Does not require adjustment to axial compressions to cater for offset caused by bearing wear.
- Works in a back-to-back arrangement to keep oil in and water out.
- Efficiently seals shafts that run eccentrically on worn bearings.
- Easy to retrofit using our special OSJ® (On-Site Joining) method.
- Significantly reduces turbine downtime and maintenance costs.
- Design is based on our highly successful Solosele® G single element seal (see pages 12-13), widely renowned for its compact, robust construction and high integrity sealing under difficult mechanical conditions.

## Typical applications

Solosele KB Hydro has operated with great success for many years on the blade roots of Kaplan water turbines at hydroelectric schemes across the world — both as an OEM fit and as retrofit on older equipment.

It has out-performed and run significantly longer than many multi-lip seals and other types at these sites.



## Operation

A Solosele KB Hydro sealing arrangement typically comprises two seals fitted back-to-back in the blade root housing. This keeps lubricant in the system and prevents the ingress of water and abrasive particles.

When the seal is installed in its housing, the radial squeeze on its elastomeric body provides low pressure sealing suitable for stationary and turbine start-up conditions.

As system pressure rises, the seal responds accordingly to maintain a constant sealing force through fluctuating and reversing pressure differentials (including negative pressure) between the oil and water. In addition, the seal's highly developed profile enables it to overcome high levels of eccentricity or shaft offset caused by bearing wear at the blade root.

## Installation

Solosele KB Hydro does not need axial compression, therefore housing length tolerances can be relaxed and installation becomes a very simple procedure. This is particularly valuable to OEMs when fitting endless-type seals during plant assembly.

## On-Site Joining

Days of unnecessary turbine downtime and associated labour costs are saved when you fit Solosele KB Hydro + OSJ.

Using our special On-Site Joining (OSJ) method, the split single-element Solosele KB Hydro is efficiently joined to form an endless seal around a shaft. Our method gives you the performance of a fully moulded seal with the maintenance benefits of a split seal — at *best value* price.

We developed this system to help customers who wanted a simple yet highly efficient seal that could be fitted swiftly and easily on site without removing the blade. Before Solosele KB Hydro + OSJ, the only answer was to use an expensive split multi-lip seal that demanded great skill in fitting to obtain effective results.

## Training for On-Site Joining

Successful application of the Solosele KB Hydro + OSJ method relies on careful adherence to all stages of the joining process.

This process is described step-by-step in the full fitting instructions supplied with each seal kit.

However, we recommend that first-time users attend one of our hands-on training sessions. These can be carried out on-site or at any of our premises worldwide.

# Solosele® KB Hydro special duty seal

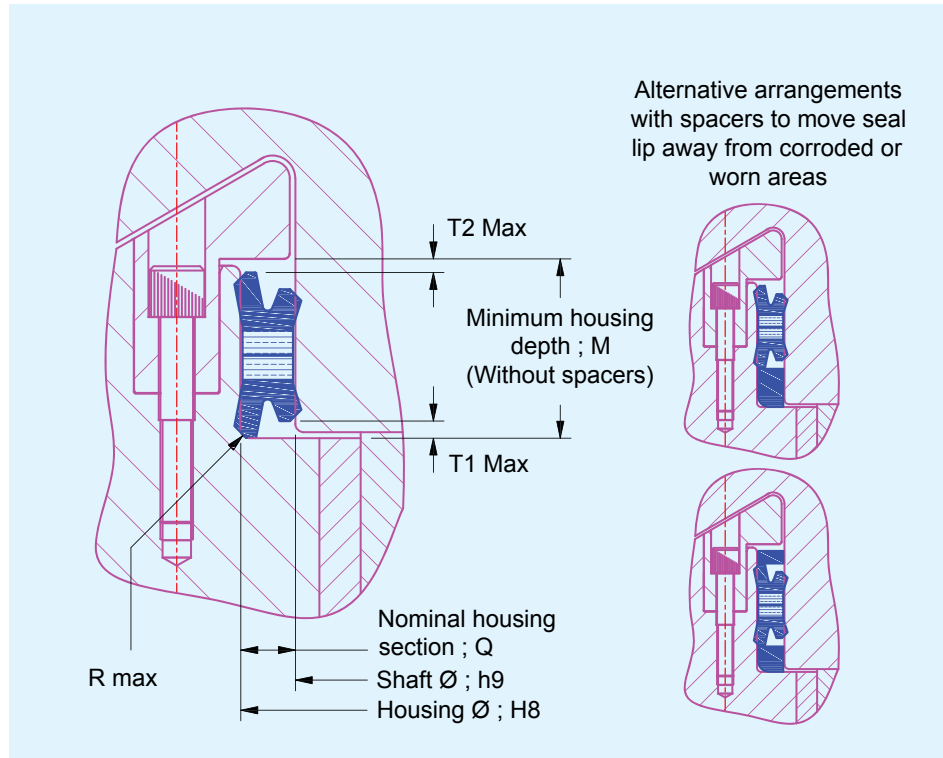

Solosele® KB Hydro — Housing & seal configuration

Solosele® KB Hydro — Recommended dimensions

Nominal housing section 'Q' (Seal section)	Maximum tolerance on housing section 'Q'	Maximum shaft diameter 'h9' (See 'How Supplied')	Lead-In Chamfer Depth 'T1' Max	Lead-In Chamfer Depth 'T2' Max	Minimum housing depth 'M' (Without spacer rings)	'R' max
mm/inch	mm/inch	mm/inch	mm/inch	mm/inch	mm/inch	mm/inch
10/0.39	+0.58/0.023 -0.44/0.017	575/22.64	3.0/0.12	2.4/0.09	24/0.95	1.6/ 0.06
12.5/0.49	+0.69/0.027 -0.53/0.021	700/27.56	4.0/0.16	3.0/0.12	31/1.22	2.0/ 0.08
16/0.63	+0.81/0.032 -0.66/0.026	900/35.43	5.0/0.20	4.0/0.16	40/1.58	2.5/ 0.10
19/0.75	+1.01/0.040 -0.80/0.031	1100/43.31	6.0/0.24	4.5/0.18	47/1.85	3.0/ 0.12
25/0.98	+1.21/0.048 -0.96/0.038	Consult James Walker	8.0/0.32	6.0/0.24	64/2.52	4.0/ 0.16

## Seal availability

Solosele® KB Hydro is supplied in a number of formats:

- Endless seals that are ideal for OEM installation.
- Split seals with OSJ® (On-Site Joining) kits for retrofitting.
- In a range of radial sections to suit Kaplan blade root housings.

## Materials

We recommend our medium nitrile (NBR) elastomer for normal blade root sealing applications. This material has excellent resistance to all standard mineral oils used in this industry, and is suitable for the temperature ranges encountered by virtually all Kaplan water turbines.

## How supplied

Solosele KB Hydro is readily available in a range of radial sections and diameters. The 'Recommended dimensions' chart on this page shows the ratio of seal section to maximum diameter that we recommend.

Other section to diameter ratios can be accommodated, so if the seal dimensions you require are not listed, please consult our Technical Support Team.

## How to specify & order

Please quote **James Walker Solosele KB Hydro**, and the following (in mm):

- Seal inside diameter (ie, shaft diameter 'h9')
- Nominal housing section 'Q' (ie, seal section)
- Minimum housing depth 'M' (without spacers).
- Also note any special considerations concerning your application.

Then contact your local James Walker company or distributor. They will provide expert technical advice, and are more than willing to discuss the exact details of your application before you place an order.

## Tube test seals

### Tube test seals

*High-pressure hydrostatic testing*

We manufacture two types of seal that are specifically designed to operate with tube testing machines that repeatedly seal and release the tube ends as part of the hydrostatic testing process.

The quality of such seals is a crucial factor in the reliability of the machines' operation; our tube test seals therefore provide the highest levels of performance.

Other designs are available on request.



### Polyurethane seals

#### Description

These are manufactured from high tensile, impact resistant polyurethane. They provide excellent wear resistance and will operate at high or low pressures. A special lip profile is incorporated to enable tube entry without seal damage.

#### Special features

- Dual or single hardness seals.
- Colour coded for different test regimes — test heads or pressure.
- Excellent record of reliability.
- Extremely wear resistant.
- Special lip profile for maximum seal life.

#### Dual hardness seals

In addition, our fully-moulded dual hardness seals offer:

- Improved anti-extrusion properties.
- Longer working life.
- Improved tolerance of poor mechanical conditions.

#### Operating capability

- **Maximum operating pressure:** these seals are regularly used at pressures in excess of 100MPa (14,500psi) with thick-walled high pressure rated steel tubes.

#### How supplied

Custom manufactured to any size. We also hold a vast number of mould tools covering most standards.

### Tube Test Seal Type S

#### Description

This is moulded in wear-resistant elastomer-proofed fabric. The seal back is a hard grade of reinforced proofed fabric that provides considerable torsional rigidity. The back is fully moulded to lips of a more flexible proofed fabric, for high sealing integrity.

A taper on the outside lip ensures efficient sealing even though an axial float of the seal is permitted.

#### Special features

- Self-energising seal that does not require axial compression.
- Small seal sections compatible with long seal life.
- Minimum shutdown time for seal replacement.
- Ease of test head maintenance.

#### Operating capability

- **Maximum operating pressure:** 69MPa (10,000psi).

#### How supplied

Custom manufactured to any size. Standard sizes available for tubes of nominal bore from 42.2mm (1.66 in) to 431.8mm (17 in).

## Self-aligning Gland Rings

## Self-aligning Gland Rings

*For arduous conditions*

**Description**

**Our Self-aligning Gland Rings are designed for use with heavy-duty hydraulic packings where conditions are particularly arduous.**

Each set comprises two triangular section rings of wear-resistant engineering thermoplastic. Under system pressure, these slide apart from each other in a controlled manner to absorb wear and off-set in the system.

**Typical applications**

Available as an optional feature with the following hydraulic sealing products:

- Chevron®.
- Lion® Expanding Packing.
- Lofilm®.
- Lofilm® HD.

They are recommended for plant with:

- Heavily worn rams.
- Large degrees of shaft off-set.
- Large extrusion gaps between the gland follower and ram.

**Materials of construction**

Manufactured as standard in high strength, wear-resistant nylon. Special water-resistant grades of nylon are available on request.

**How supplied**

Each set is usually supplied as two split rings, manufactured for the specific application.

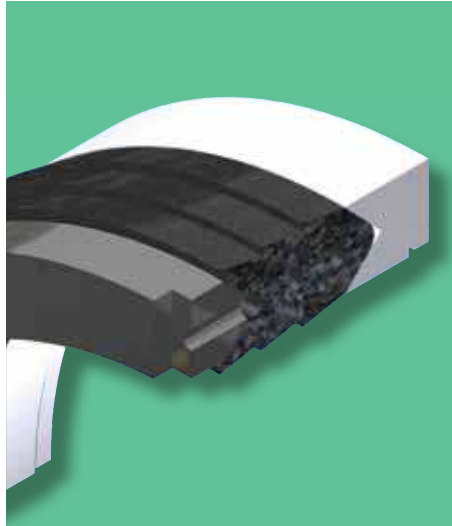

*Self-aligning Gland Ring for piston sealing fitted to a Chevron® set*

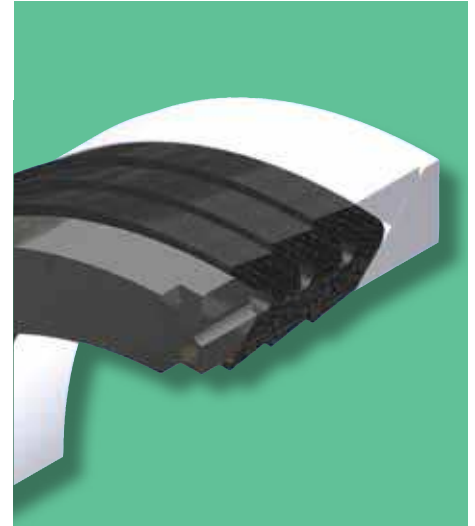

*Self-aligning Gland Ring for shaft sealing fitted to a Chevron® set*



*Self-aligning Gland Ring for piston sealing*

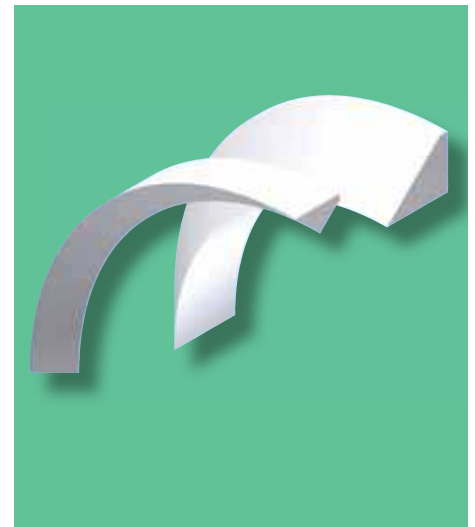

*Self-aligning Gland Ring for shaft sealing*

## Lionsele® W1 wiper for rods

### Lionsele® W1

Wiper for aggressive environments

#### Description

**Lionsele® W1 is a medium duty wiper that has excellent abrasion resistance to cope with the most aggressive contaminants, whilst causing minimal wear to shaft surfaces.**

Manufactured from high performance polyurethane (AU/EU), this product has a single robust lip that provides a simple and highly effective wiping action. It is designed to be clamped into a housing.

#### Special features

- Medium duty wiper for mud, sand, etc.
- Excellent wear resistance in aggressive environments.
- Tough polyurethane construction for a long working life.

#### Typical applications

This single-acting rod wiper is typically used in conjunction with a suitable rod seal — eg, Lionsele® G, Lionsele® U2 or Lofilm® — on medium duty hydraulic systems.

#### Operating capabilities

- **Temperature range:**  
-30°C to +100°C (-22°F to +212°F).

#### Materials of construction

Precision moulded in wear-resistant polyurethane (AU/EU).

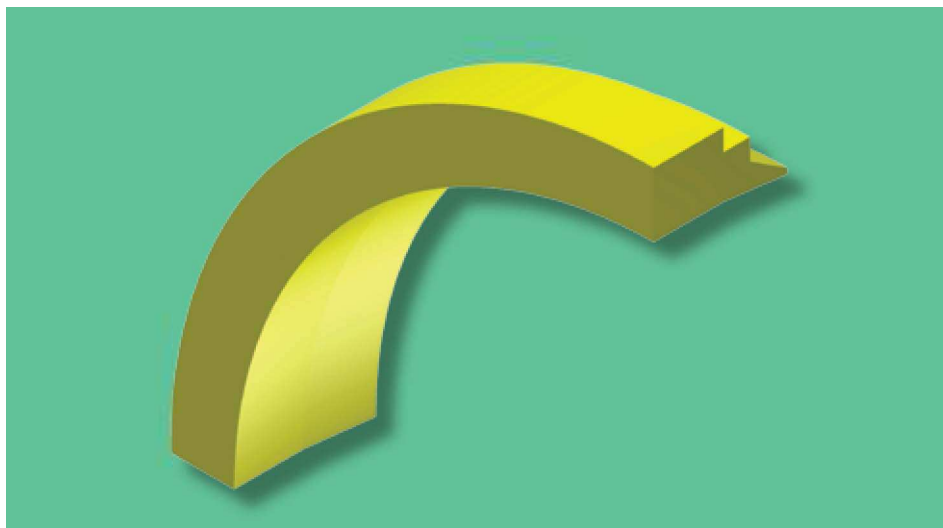

#### Media capabilities

Lionsele W1 is suitable for use with most mineral-based hydraulic fluids at up to 100°C (212°F). It is also suitable for exposure to air, water, and most lubricating oils and greases.

Before use with fire-resistant fluids of the water/oil emulsion or water/glycol types, please consult our Technical Support Team for advice on temperature limits.

#### How supplied

(Also see *Hydraulic sealing products — Size charts*, which can be downloaded from [www.jameswalker.biz](http://www.jameswalker.biz))

This wiper is available as standard for installation in housings to BS ISO 6195 Type A. Other sizes can readily be supplied.

Fitting instructions supplied with each pack of wiper rings.

#### Lionsele® W1 typical housing

See *Appendix O (page 69)* for preferred housing designs to BS ISO 6195 Type A.

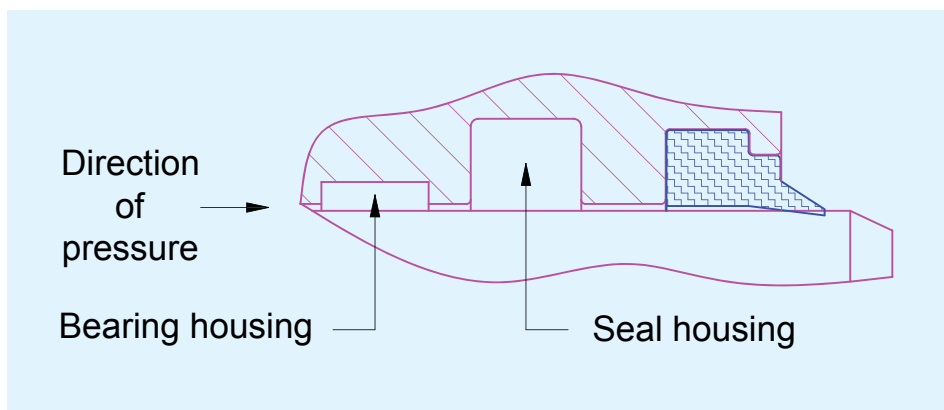



## Lionsele® W2 wiper for rods

## Lionsele® W2

Self-retaining wiper for open housings

**Description**

Lionsele® W2 is a self-retaining single acting rod wiper with an integral metal case. The metal case enables the wiper to be fitted in an open housing, thus reducing the cost of the hydraulic assembly.

The mechanical strength and abrasion resistance of the high performance polyurethane element enables the wiper lip to operate efficiently with a long working life.

**Special features**

- Medium to heavy duty applications.
- Self-retaining design for simple open-faced housings.
- Tough, wear resistant polyurethane lip for long working life.

**Typical applications**

This single-acting rod wiper is typically used in conjunction with a suitable rod seal — eg, Lionsele® G, Lionsele® U2 or Lofilm® — on medium to heavyweight hydraulic systems.

**Operating capabilities**

- **Temperature range:**  
-30°C to +100°C (-22°F to +212°F).

**Materials of construction**

Precision moulded in wear-resistant polyurethane (AU/EU). Metal casing material is stainless steel, with other metal grades available.

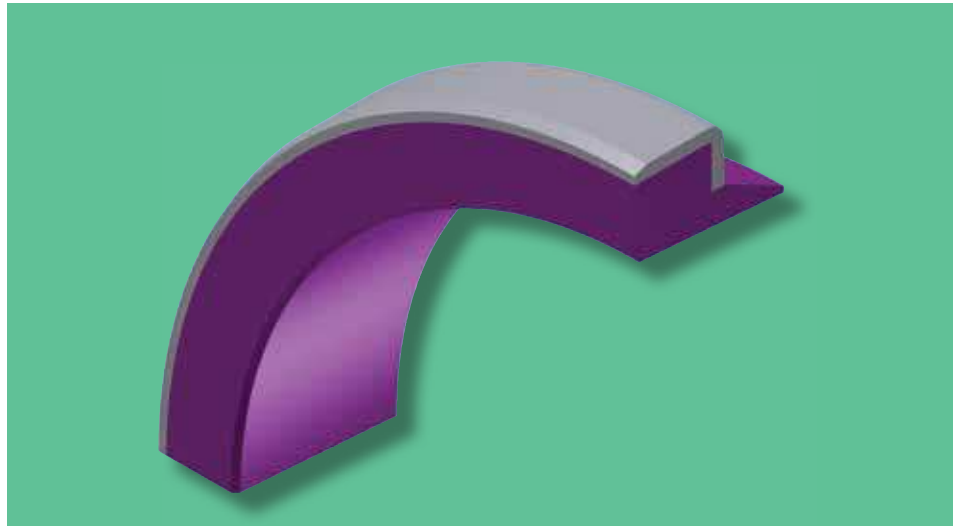
**Media capabilities**

Lionsele W2 is suitable for use with most mineral-based hydraulic fluids at up to 100°C (212°F). It is also suitable for exposure to air, water, and most lubricating oils and greases.

Before use with fire-resistant fluids of the water/oil emulsion or water/glycol types, please consult our Technical Support Team for advice on temperature limits.

**How supplied**

(Also see *Hydraulic sealing products — Size charts*, which can be downloaded from [www.jameswalker.biz](http://www.jameswalker.biz))

This wiper is available as standard for installation in housings to BS ISO 6195 Type B. Other sizes can readily be supplied.

Fitting instructions are supplied with each pack of wiper rings.

**Lionsele® W2 typical housing**

See Appendix P (page 70) for preferred housing designs to BS ISO 6195 Type B.

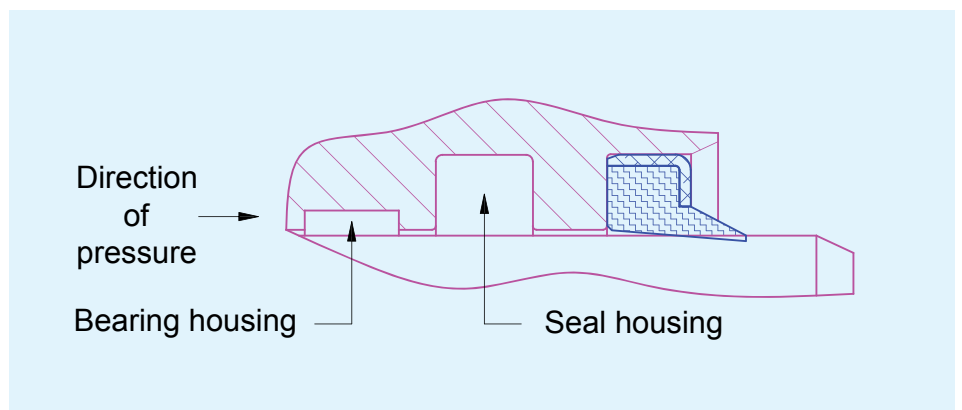

## Lionsele® W3 wiper for rods

### Lionsele® W3 Double-acting wiper

#### Description

**Lionsele® W3 is a double-acting wiper manufactured from tough, wear resistant polyurethane (AU/EU).**

Its robust outer wiper lip excludes contaminants from the hydraulic system, and the internal wiper lip collects fluids that bypass the primary rod seal, to give dry rod performance.

#### Special features

- Double-acting for contamination exclusion and dry rod performance.
- Chamfered sealing lips provide minimum fluid film conditions.
- Moulded in high performance polyurethane.

#### Typical applications

This double-acting wiper is typically used in conjunction with a suitable rod seal — eg, Lionsele® G, Lionsele® U2 or Lofilm®. It is invaluable for applications where the residual film of fluid left on the rod by the primary seal cannot be tolerated.

#### Operating capabilities

- **Temperature range:**  
-30°C to +100°C (-22°F to +212°F).

#### Materials of construction

Precision moulded in wear-resistant polyurethane (AU/EU).



#### Media capabilities

Lionsele W3 is suitable for use with most mineral-based hydraulic fluids at up to 100°C (212°F). It is also suitable for exposure to air, water, and most lubricating oils and greases.

Before use with fire-resistant fluids of the water/oil emulsion or water/glycol types, please consult our Technical Support Team for advice on temperature limits.

#### How supplied

(Also see *Hydraulic sealing products — Size charts*, which can be downloaded from [www.jameswalker.biz](http://www.jameswalker.biz))

This wiper is available as standard for installation in housings to BS ISO 6195 Type C. Other sizes can readily be supplied.

Fitting instructions are supplied with each pack of wiper rings.

#### Lionsele® W3 typical housing

See *Appendix Q (page 71)* for preferred housing designs to BS ISO 6195 Type C.

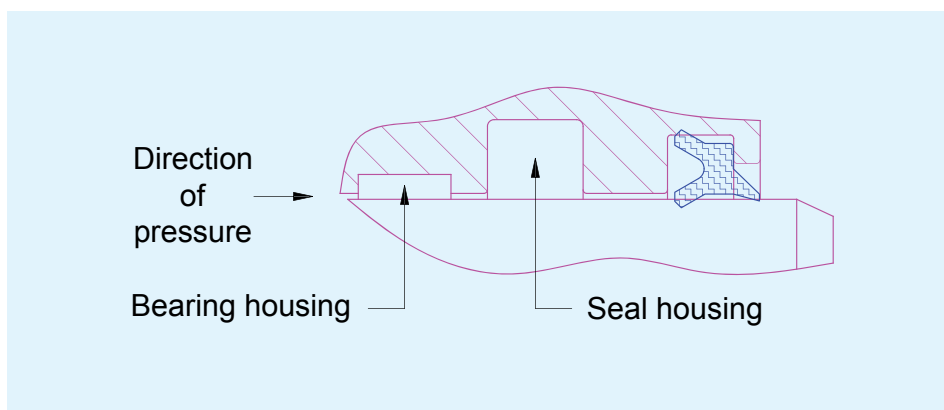

# Wyclip® scraper ring & wiper for rods

## Wyclip®

Heavy-duty scraper/wiper

### Description

**Wyclip® is our highly popular clip-in scraper/wiper that proves very effective for removing the most abrasive and tenacious foreign matter from rods.**

A remarkably simple design enables the Wyclip ring to be housed with the minimum machining of metal parts. Only an annular recess is needed for the housing — no retaining plates or fixing bolts are required.

The ring is simply pressed into position. Positive retention is ingeniously achieved by its outer lip springing into position behind the recess shoulder.

### Special features

- Powerful scraping action for highly efficient removal of abrasive particles.
- Excludes contaminants.
- Very simple to fit with clip-in action.
- Hardwearing for long working life.
- Remains in contact with the rod under the most demanding conditions.

### Typical applications

Heavy-duty operations on jack rods of earth-moving plant and other construction equipment, forklift trucks, and any other items of industrial plant that work in arduous conditions and need a robust rod scraper/wiper.

### Operating capabilities

- **Temperature range** (standard material): -40°C to +100°C (-40°F to +212°F).

### Materials of construction

**Standard material:** a specially developed semi-rigid, yet resilient, hardwearing thermoplastic.

**Special materials:** PTFE, acetal and other materials are available on request.



### Media capabilities

**Standard materials** are suitable for use with most mineral based hydraulic fluids, and most fire-resistant fluids of the water/oil emulsion or water/glycol types at temperatures up to 100°C (212°F). They also resist air, water, and most lubricating oils and greases.

**Special materials** extend considerably the range of application in terms of temperature and fluid compatibility. Please consult our Technical Support Team.

### How supplied

(Also see *Hydraulic sealing products — Size charts*, which can be downloaded from [www.jameswalker.biz](http://www.jameswalker.biz))

Readily available in endless form only, in standard materials and a wide range of metric and inch sizes.

Rings to other sizes, or in special materials, are manufactured to order.

Fitting instructions are supplied with each pack of rings.

### Wyclip® typical housing

See Appendix R (page 72) for preferred housing designs.

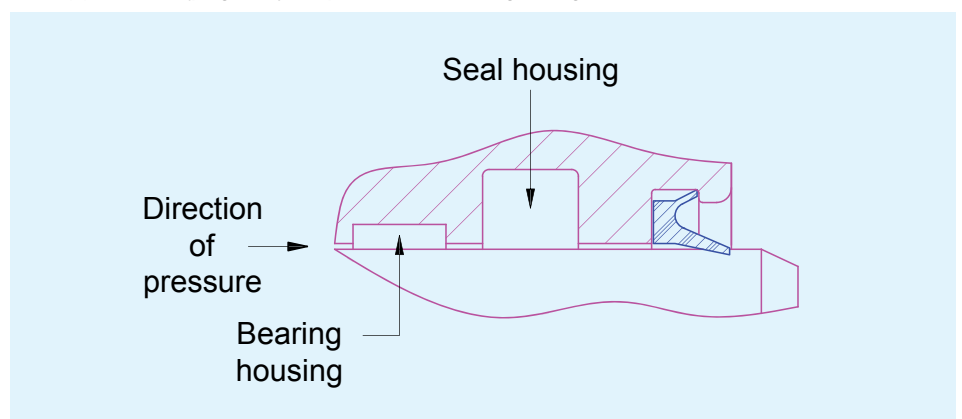

# Wiper Type L for rods

## Wiper Type L

Robust wiper for highly abrasive media

### Description

Our Wiper Type L rings are designed to limit the ingress of foreign matter in the area of the seal housing on a wide variety of reciprocating hydraulic systems.

Manufactured in a versatile elastomer-proofed fabric, these rings provide an effective wiping action whilst being tough and resistant to the wear encountered in such applications.

### Special features

- Effective wiping action in abrasive media.
- Tough rubberised fabric construction.
- Hardwearing for long working life.
- Extensive standard range.

### Typical applications

Heavy-duty wiping operations on a wide range of reciprocating plant and equipment.

### Operating capabilities

- **Temperature range** (standard materials): -35°C to +120°C (-31°F to +248°F).
- Non-standard materials can increase the temperature range. Please consult our Technical Support Team.

### Materials of construction

**Standard material:** cotton fabric proofed with nitrile (NBR) rubber.

**Special materials:** include cotton fabric proofed with fluorocarbon (FKM); and solid rubber.

### Media capabilities

**Standard materials** are suitable for use with most mineral based hydraulic fluids, and most fire-resistant fluids of the water/oil emulsion or water/glycol types at temperatures up to 120°C (248°F). They also resist air, water, and most lubricating oils and greases.

**Special materials** extend considerably the range of application in terms of temperature and fluid compatibility. Please consult our Technical Support Team.

### How supplied

(Also see Hydraulic sealing products — Size charts, which can be downloaded from [www.jameswalker.biz](http://www.jameswalker.biz))

Readily available in split and endless form in standard materials and a wide range of sizes.

Rings to other sizes, within the range 8mm (0.32 in) shaft to 1960mm (77.2 in) flange OD, or in special materials, are manufactured to order, but tooling charges may be incurred.

Fitting instructions are supplied with each wiper ring.



### Wiper Type L typical housing

See Appendix S (pages 73-74) for preferred housing designs.

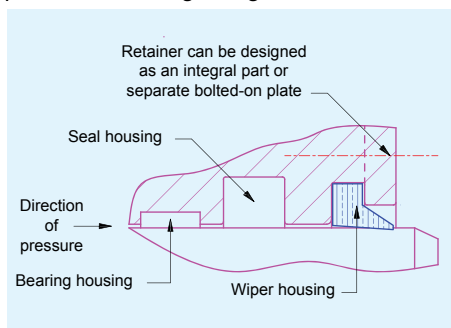

### General profile

Whilst rings of the general profile, as in diagram, can be made to suit individual customer requirements, our preferred cross-sectional profiles are shown in the accompanying table.

Each of the five profiles covered in the table can be made to suit specific shaft diameters. The table shows the recommended range of use for each profile.

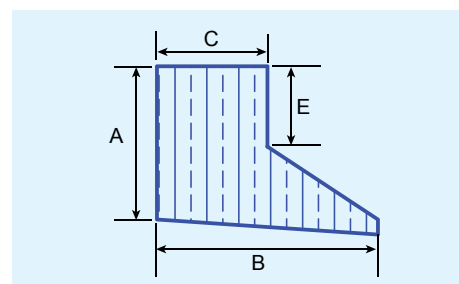

### Preferred profiles and sizes

JW profile Chart number	Profile dimensions (mm)				Preferred Ø range (mm)	
	A	B	C	E		
524***	5.90	8.00	4.00	3.00	25.00 >	≤ 100.00
525***	6.70	12.00	7.00	3.50	> 100.00	≤ 250.00
526***	8.00	15.00	7.50	4.60	> 250.00	≤ 400.00
527***	11.00	18.00	8.00	6.00	> 400.00	≤ 600.00
528***	15.00	22.00	11.00	8.00	> 600.00	-

\*\*\*A large selection of sizes that do not comply with these preferred dimensional constraints are also available. Refer to James Walker for advice.

## Lionsele® B1 bearing strip

## Lionsele® B1

Very low friction for high speeds

**Description**

Lionsele® B1 is our bearing strip with a very low coefficient of friction for high speed duties. This tape-type bearing material is used within a hydraulic system when relative movement needs to be accommodated between two metallic surfaces.

This plain rectangular strip of bronze-loaded PTFE provides a cost-effective and easy-to-use alternative to traditional materials such as phosphor bronze or lead.

**Special features**

- Self-lubricating to provide low dynamic and breakout friction.
- Suitable for high speed applications.
- High fatigue strength for long service life and reduced downtime.
- Dampens mechanical vibrations.
- Versatile and easy to assemble.

**Typical applications**

Often used in conjunction with compact-type piston head seals in hydraulic systems to eliminate metal-to-metal contact and other problems associated with offset pistons.

**Operating capabilities**

- **Maximum bearing stress** at RT (static duty): 25MPa (3626psi).
- **Maximum bearing stress** at RT (dynamic duty): 12MPa (1740psi).
- **Temperature range:** -60°C to +150°C (-76°F to +302°F); or +200°C (+392°F) with severely restricted load carrying capacity on dynamic duties.
- **Maximum recommended relative velocity:** 5.0m/s (984fpm).

**Materials of construction**

Bronze-loaded PTFE.

**Media capabilities**

Chemically compatible with commonly used hydraulic fluids. (If in doubt, please consult our Technical Support Team.)

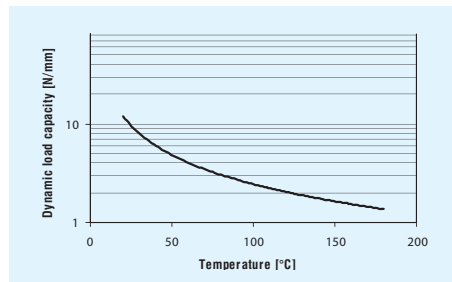
**Dynamic load carrying capacity at operating temperature****Bearing selection****Tape width**

This is determined by the formula:

$$\text{Width} = kF_{\text{max}}/nq$$

Where

**F** = maximum side load to be supported by the bearing (N). This is the function of rod and piston weight, cylinder/piston geometry, side loads applied to rod, etc.

**k** = safety factor (k=2 is recommended).

**n** = number of bearings required.

**q** = material load carrying capacity in N/mm<sup>2</sup> (MPa) at operating temperature.

See graph above.

**d** = rod or cylinder diameter (mm).

From the chart in our pdf document *Hydraulic sealing products — Size charts*, (see How supplied) select the closest standard width. Check that rod/cylinder diameter is in the specified min/max diameter range for that particular selected width. If not, n+1 of next smallest width should be selected. The width should be rounded up to the nearest ISO size.

**Tape length**

Allowance must be made for thermal expansion when determining tape length, so that the minimum gap is left between tape ends when tape is installed. This also prevents hydrodynamic pressure build-up.

$$\text{Tape length (rod)} = \pi(\text{Ø}d + S) - T$$

$$\text{Tape length (piston)} = \pi(\text{Ø}D - S) - T$$

Where:

**S** = tape thickness (mm).

**T** = gap (mm) between tape ends.

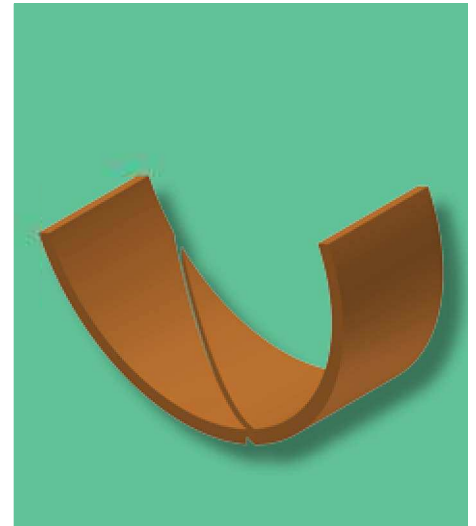

Recommended gap T between tape ends when bearing strip is installed should be as follows:

Cylinder/Rod diameter (mm)	Gap T (mm)
Up to 25	2.0
25 to 50	3.0
50 to 125	6.0
125 to 150	12.0
150 to 500	20.0

**Tape thickness**

Tape thickness varies according to tape width. Note that thin strip dissipates heat more efficiently and therefore the thermal expansion will be less.

**Bearing strip cutting**

The standard type of cut is 45° scarf split. Other types of cut are available.

**How supplied**

(Also see *Hydraulic sealing products — Size charts*, which can be downloaded from [www.jameswalker.biz](http://www.jameswalker.biz))

Available in length form by the metre to suit BS ISO 10776 housing widths and radial sections. Also precision-manufactured to order as machined split bearings. Fitting instructions are supplied with each pack.

**Lionsele® B1 housings**

See Appendix T (pages 75-76) for preferred housing designs to BS ISO 10766.

# Lionsele® B2 bearing strip

## Lionsele® B2

For heavy-duty applications

### Description

Lionsele® B2 bearing strip has a low coefficient of friction. The tape-type bearing material is used within a hydraulic system when relative movement needs to be accommodated between two metallic surfaces.

This plain rectangular strip of synthetic fabric impregnated with thermosetting resin provides a cost-effective and easy-to-use alternative to traditional materials such as phosphor bronze or lead.

### Special features

- Self-lubricating to provide low dynamic and breakout friction.
- High resistance to wear.
- Suitable for heavy-duty applications.
- High strength material that offers long life and damping of mechanical vibrations to reduce plant downtime.
- Versatile and easy to assemble.

### Typical applications

Often used in conjunction with compact-type piston head seals in hydraulic systems to eliminate metal-to-metal contact and other problems associated with offset pistons.

### Operating capabilities

- **Maximum bearing stress** at RT (static duty): 400MPa (58,015psi).
- **Maximum bearing stress** at RT (dynamic duty): 90MPa (13,053psi).
- **Temperature range:** -60°C to +100°C (-76°F to +212°F); or +130°C (+266°F) with severely restricted load carrying capacity on dynamic duties.
- **Maximum recommended relative velocity:** 1.0m/s (196.9fpm).

### Materials of construction

Synthetic fabric impregnated with thermosetting resin.

### Media capabilities

Chemically compatible with commonly used hydraulic fluids. (If in doubt, please consult our Technical Services Team.)

### Dynamic load carrying capacity at operating temperature

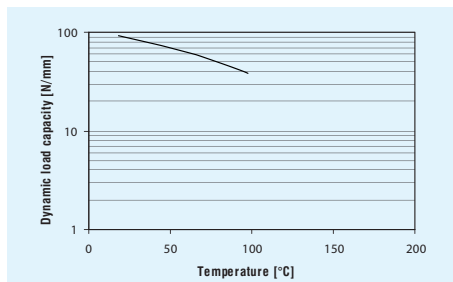

### Bearing selection

#### Tape width

This is determined by the formula:

$$\text{Width} = kF_{\text{max}}/nq_d$$

Where

**F** = maximum side load to be supported by the bearing (N). This is the function of rod and piston weight, cylinder/piston geometry, side loads applied to rod, etc.  
**k** = safety factor (k=2 is recommended).  
**n** = number of bearings required.  
**q** = material load carrying capacity in N/mm<sup>2</sup> (MPa) at operating temperature. See graph above.  
**d** = rod or cylinder diameter (mm).

From the chart in our pdf document *Hydraulic sealing products — Size charts*, (see How supplied) select the closest standard width. Check that rod/cylinder diameter is in the specified min/max diameter range for that particular selected width. If not, n+1 of next smallest width should be selected. The width should be rounded up to the nearest ISO size.

#### Tape length

Allowance must be made for thermal expansion when determining tape length, so that the minimum gap is left between tape ends when tape is installed. This also prevents hydrodynamic pressure build-up.

$$\begin{aligned} \text{Tape length (rod)} &= \pi(\phi d + S) - T \\ \text{Tape length (piston)} &= \pi(\phi D - S) - T \end{aligned}$$

Where

**S** = tape thickness (mm)  
**T** = gap (mm) between tape ends

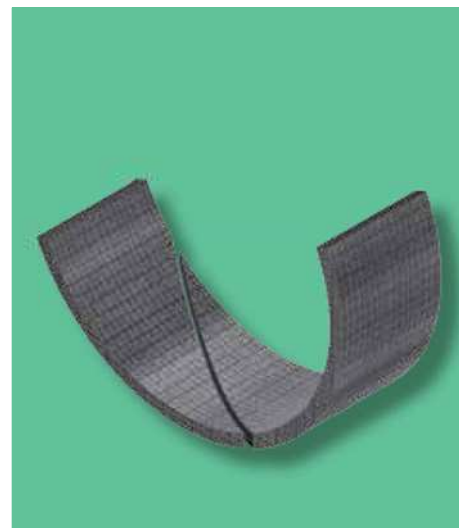

Recommended gap T between tape ends when bearing strip is installed should be as follows:

Cylinder/Rod diameter (mm)	Gap T (mm)
Up to 25	2.0
25 to 50	3.0
50 to 125	6.0
125 to 150	12.0
150 to 500	20.0

### Tape thickness

Tape thickness varies according to tape width. Note that thin strip dissipates heat more efficiently and therefore the thermal expansion will be less.

### Bearing strip cutting

The standard type of cut is 45° scarf split. Other types of cut are available on request.

### How supplied

(Also see *Hydraulic sealing products — Size charts*, which can be downloaded from [www.jameswalker.biz](http://www.jameswalker.biz))

Available in length form by the metre to suit BS ISO 10776 housing widths and radial sections. Also precision-manufactured to order as machined split bearings. Fitting instructions are supplied with each pack.

### Lionsele® B housings

See Appendix T (pages 75-76) for preferred housing designs to BS ISO 10766.

# Comflex® Fabric Reinforced Bellows

## Comflex® Fabric Reinforced Bellows

*Hydraulic ram protectors*

### Description

**These heavy-duty bellows are based on elastomer-proofed fabrics, and feature a totally vulcanised construction that provides a particularly rugged product.**

During construction, various layers of elastomer-proofed fabric are preformed prior to the vulcanising process. By using this technique, we avoid the weaknesses that are inherent in bellows which are fabricated from separate pieces and joined by stitching or other mechanical means.

### Special features

- Protect exposed metal surfaces from abrasive matter and other contaminants in dynamic applications.
- Withstand rapid motion and heavy vibration.
- Materials and designs are available to suit many different industrial environments.
- Split configurations can be supplied for ease of maintenance.



### Typical applications

Comflex® Reinforced Fabric Bellows are well proven as heavy-duty protectors in many different industries.

They are particularly favoured as protectors for hydraulic rams and cylinders working in aggressive environments such as steelworks and power generation plant.

Examples include:

- Forging and extrusion presses.
- Raw materials handling plant.
- Discharge rams.
- Hydraulic compactors.
- Pulverised fuel mills.
- Rolling mills.

### Materials of construction

Full range of base fabrics and elastomers is available to suit different mechanical, chemical and temperature conditions.

### How supplied

Bellows design, open/close ratios, stroke length, convolution width, split or endless configuration, materials, etc, are selected to suit the application.

Supplied circular, oval, rectangular or any other reasonable cross section, and in all sizes from 38mm (1½ inch) ID upwards without upper limit.

# 'O' rings

## 'O' rings

Highly versatile sealing devices

### Description

The seemingly humble 'O' ring, or toroidal seal, is a highly versatile device that is rated as the world's most popular volume produced fluid seal.

James Walker has been manufacturing top quality 'O' rings since this sealing method was introduced in the 1930s. Today we stock thousands of types and sizes of 'O' rings ready for same-day despatch. Any non-stocked items can be precision manufactured within hours, if necessary, to meet industry's most urgent demands.

Although many other seals will perform the same functions, the popularity of the 'O' ring is greatly influenced by commercial considerations. For example, when a less compact type of seal is used, the components that house it are larger and more expensive. This, in turn, makes the complete unit more bulky and costly than if a compact 'O' ring had been used.

### 'O' ring features

- Suits many static and dynamic duties.
- Seals efficiently in both directions — therefore only one seal is usually needed for double-acting applications.
- Occupies little space.
- Simple housing design makes it very easy and inexpensive to incorporate 'O' rings into equipment design.
- Low cost in comparison to other sealing methods.
- Available in a vast range of elastomers and polymers to suit virtually any fluid media.

### Typical applications

**Static seals** suitable for many hydraulic cylinder assemblies and hydraulic plant in general.

**Dynamic seals** for pistons operating in light duty applications.

### Operating capabilities

- **Maximum operating pressure:** typically 10MPa (1450psi), depending on application. When used in conjunction with back-up rings, the pressure limit can be extended to at least 35MPa (5075psi).

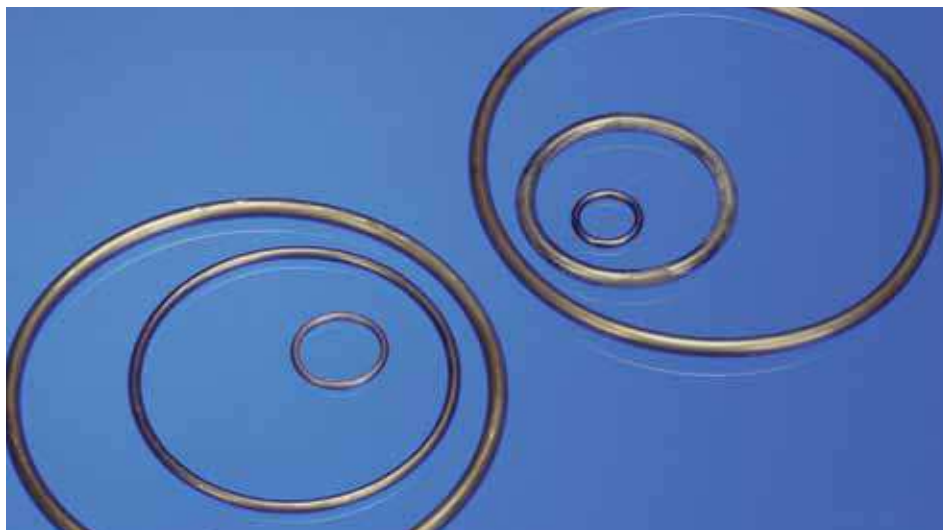

- **Temperature range:** 'O' rings can work between -60°C and +315°C (-76°F and +599°F) when made of elastomer — according to material grade. PTFE 'O' rings can function at temperatures down to -200°C (-328°F).
- **Maximum surface speed:** modest — to lessen the potential of the ring twisting or rolling in its housing.

### Materials of construction

We precision-mould 'O' rings in over 100 different grades of general and high-performance elastomers. In addition, we supply them in PTFE, and as an elastomeric core encapsulated in FEP.

We stock wide ranges in the following general elastomer grades:

- Nitrile (NBR) **PB80**.
- Ethylene-propylene (EPM) **EP18/H/75**.
- Silicone (VMQ) **SIL 80/2**.

High-performance elastomers for our stocked ranges include:

- Hydrogenated nitrile (HNBR) grades **Elast-O-Lion® 101, 180 and 985**. Grades 101 and 985 are compounded for rapid gas decompression (RGD) resistance.
- Fluoroelastomer (FKM) grades **FR10/80, FR25/90, FR58/90 and FR68/90**. The latter three grades are compounded for rapid gas decompression (RGD) resistance.

**Back-up rings** are supplied in Fluolion® (virgin or filled PTFE), and PEEK™. Standard design is a spiral of two turns.

### Media capabilities

As our range of 'O' ring materials is so extensive, please refer to our **Chemical compatibility chart** on pages 50-51.

### How supplied

Please ask for our 'O' Ring Guide that gives full details of standards, sizes and materials. This can also be downloaded in pdf format from [www.jameswalker.biz](http://www.jameswalker.biz).

Size ranges in our standard charts are:

- SAE AS 568 (inch sizes).
- BS ISO 3601-1 (metric and inch sizes).
- BS ISO 3601-1 Aerospace sizes.
- BS 1806 (inch sizes, now superseded by BS ISO 3601-1 Class A).
- BS 4518 (metric sizes).
- JW Chart 17000 (inch sizes).

We have an 'O' ring mould library of 10,000 tools. If you cannot find an 'O' ring in any of the above ranges to meet your needs, we will precision mould non-standard items to order, including endless rings up to 2.2m (87 inch) OD.



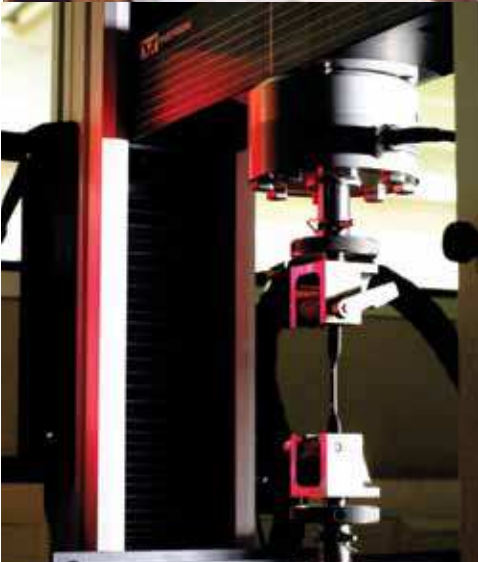
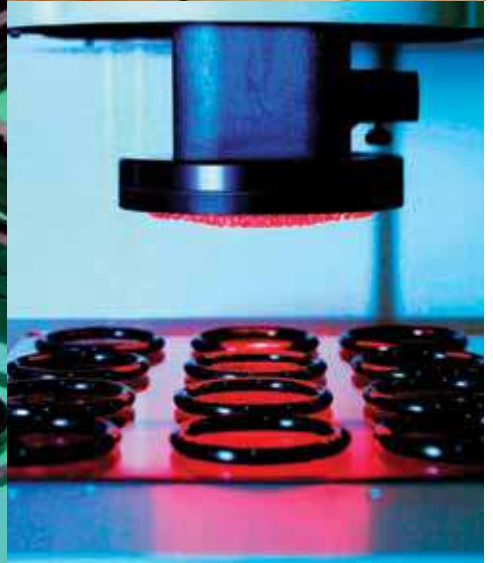

# Chemical compatibility chart

**KEY: 1 = VERY GOOD 2 = GOOD 3 = POOR 4 = CONSULT JAMES WALKER X = NO DATA**

	RUBBER										
	Acrylic (ACM)	Aflas® (FEPM)	Butyl (IIR)	Chloro-sulphonyl polyethylene (CSM)	Elast-O-Lion® (HNBR)	Epichlorohydrin (ECO)	Ethylene propylene (EPM/EPDM)	Fluoro-elastomers (FKM) *G	Fluoro-silicone (FVMQ)	Kalrez® (FFKM)	Natural rubber (NR)
Air & oxygen	2	1	1	1	1	1	1	1	1	1	2
Water < 80°C	3	1	1	2	1	1	1	1	1	1	1
Water > 80°C	3	1*F	1	2	1	2	1	4	2	1	2
Salt water	3	1	1	2	1	2	1	1	1	1	1
Acids: dilute, cold	3	1	1	1	1	3	2	1	2	1	3
Alkalis: dilute	3	1	1	1	2	2	1	2	2	1	2
Methanol	3	1	1	1	1	2	1	3*C	1	1	1
Acetaldehyde (consult JW for other aldehydes)	3	1	1	3	2	3	1	3*C	3	1	2
Ethylene diamine	3	1	1	3	2	1	1	3*C	3	1	1
Other amines	3	4	3	3	4	X	3	3	3	1	3
Chlorinated solvents	3	3	3	3	3	3	3	1	2	1	3
Ethers	3	3	3	3	3	3	3	3*C	3	1	3
Ketones	3	3	1	3	3	3	1	3*C	3	1	3
Hydrocarbons: aliphatic	2	1	3	3	1	1	3	1	1	1	3
Hydrocarbons: aromatic	3	4	3	3	4	3	3	1	2	1	3
Petrol/gasoline: leaded	2	2	3	4	2	1	3	1	2	1	3
Kerosene	2	1	3	3	1	1	3	1	1	1	3
Animal oil & fat	1	1	2	3	1	1	2	1	1	1	3
Fuel oil & diesel	1	2	3	3	2	2	3	1	1	1	3
Lubricating oil: mineral	1	1	3	3	1	1	3	1	1	1	3
Lubricating oil: synthetic	2	2	3	3	1	3	3	2	2	1	3
Silicone oil & grease	1	1	1	1	1	1	1	1	1	1	1
Vegetable oil	1	1	3	2	1	1	3	1	1	1	3
Hydraulic fluids: mineral	1	1	3	3	1	1	3	1	2	1	3
<b>HYDRAULIC FLUIDS: Fire resistant</b>											
Chlorinated: HFD-S	3	3	3	3	3	3	3	2	2	1	3
Oil in water emulsions: HFA	3	1	3	3	2	2	3	1	2	1	3
Water in oil emulsions: HFB	3	1	3	3	2	2	3	1	2	1	3
Water/glycol based: HFC	3	1	1	1	2	2	1	4	2	1	1
Phosphate esters: HFD-R	3	1	1	3	3	3	1	1	2	1	3
<b>TEMPERATURE RANGE: °C (°F)</b>											
Minimum	-20(-4)	+5(+41)	-35(-31)	-30(-22)	-29(-20)*A	-30(-22)	-45(-49)	-18(0)*D	-60(-76)	-25(-13)	-50(-58)
Maximum: constant	+150 (+302)	+205 (+401)	+120 (+248)	+120 (+248)	+160 (+320)	+150 (+302)	+120 (+248)	+200 (+392)	+175 (+347)	+325 (+617)	+100 (+212)
Maximum: intermittent	+175 (+347)	+230 (+446)*F	+150 (+302)	+150 (+302)	+200 (+392)	+175 (+347)	+150 (+302)*B	+230 (+446)*D	+200 (+392)	Consult	+120 (+248)
<b>HARDNESS RANGE: IRHD</b>											
	80	70-90	60-70	65-80	50-90	70-90	50-90	50-98	60-80	70-95	40-85

**Notes:**

- \*A Low acrylonitrile content grades are available for temperatures down to -55°C (-67°F).
- \*B EPM grades are available for hot water service up to +180°C (+356°F).
- \*C Fluoroelastomer grades are available which offer resistance to these chemicals.
- \*D Fluoroelastomer grades are available for temperatures from -41°C to +250°C (-42°F to +482°F).
- \*E Polyurethane grades are also available from 60-74 Shore D hardness.
- \*F Aflas® grades are suitable for temperatures up to +260°C (+500°F) in hot water and steam.
- \*G Viton® grades are available on request.
- \*H Delrin® is available on request.

# Chemical compatibility chart

KEY: 1 = VERY GOOD 2 = GOOD 3 = POOR 4 = CONSULT JAMES WALKER X = NO DATA

RUBBER				THERMOPLASTICS								
Neoprene/ Chloroprene (CR)	Nitrile (NBR)	Polyure- thane (AU/EU)	Silicone (VMQ)	Fluolion® (PTFE)					Nylon 6	Acetal *H	UHMWPE	Polyether- ether ketone (PEEK™)
				Virgin	Glass loaded	Bronze loaded	Carbon loaded	Fluolion® Xtreme				
1	2	1	1	1	1	1	1	1	1	1	1	1
1	1	3	1	1	1	1	1	1	1	3	1	1
2	2	3	2	1	1	1	1	1	1	3	2	1
2	1	3	1	1	1	1	1	1	1	1	1	1
2	3	3	3	1	1	3	4	1	1	3	3	2
1	2	3	2	1	4	3	1	4	1	2	2	2
1	1	3	1	1	1	1	1	1	1	1	3	2
3	3	3	2	1	1	1	1	1	1	2	4	1
1	2	3	2	1	1	4	1	1	1	3	3	2
3	2	3	3	1	1	4	1	1	1	3	3	2
3	3	3	3	1	1	1	1	1	1	2	2	3
3	3	3	3	1	1	1	1	1	1	1	2	4
3	3	3	3	1	1	1	1	1	1	2	4	3
2	1	2	3	1	1	1	1	1	1	1	1	4
3	3	3	3	1	1	1	1	1	1	1	2	3
2	2	2	3	1	1	1	1	1	1	1	2	2
2	2	2	3	1	1	1	1	1	1	1	2	3
2	1	2	2	1	1	1	1	1	1	1	2	2
3	2	3	4	1	1	1	1	1	1	1	2	2
2	1	2	3	1	1	1	1	1	1	1	1	2
3	2	3	3	1	1	1	1	1	1	1	1	2
1	1	1	3	1	1	1	1	1	1	1	1	1
2	1	2	2	1	1	4	1	1	1	1	1	2
3	1	2	3	1	1	1	1	1	1	1	2	3
3	3	3	2	1	1	1	1	1	1	1	X	4
2	2	3	2	1	1	1	1	1	1	2	2	4
2	2	3	3	1	1	1	1	1	1	2	2	4
2	1	3	2	1	1	1	1	1	1	3	1	4
3	3	3	2	1	1	4	1	1	1	3	3	X
-40(-40)	-25(-13)*A	-15(+5)	-65(-85)	-200(-328)	Consult	Consult	Consult	Consult	Consult	Consult	Consult	Consult
+120 (+248)	+110 (+230)	+85 (+185)	+200 (+392)	+250 (+482)	Consult	Consult	Consult	Consult	Consult	Consult	Consult	Consult
+150 (+302)	+150 (+302)	+100 (+212)	+250 (+482)	Consult	Consult	Consult	Consult	Consult	Consult	Consult	Consult	Consult
40-90	40-90	55-95*E	40-80	Consult	Consult	Consult	Consult	Consult	Consult	Consult	Consult	Consult

**WARNING:** Please note that, due to the complexity of making a material selection for any given duty, all information provided in this document on chemical compatibility is intended only as a guide. For example, a compound compatible at low temperatures may show considerable deterioration at high temperatures; also, combinations of chemicals in a fluid medium may have detrimental effects. Actual service life will depend on type of application, whether static or dynamic, specific pressure medium, temperature cycle, time of exposure, etc. The low temperatures quoted are generally values at atmospheric pressure and may change at elevated pressures. If any doubt exists, please seek advice from James Walker.

# Machining information

The recommendations in this section for limits, fits and surface finishes are intended as a general guide when manufacturing and reconditioning equipment. These are the requirements for good seal performance, but we acknowledge that in many cases acceptable results will be obtained with values outside those stated.

The housing envelope sizes for the seals listed in this document can be obtained from the individual product sections. However, more general considerations such as tolerances, fits, extrusion clearances and surface finish requirements for optimum seal performance are common to the majority of seal types.

Thus the following information, most of which is based on BS ISO 5597 *Housings for piston and rod seals in reciprocating applications: Dimensions and tolerances*, will form a good basis for housing design in the majority of cases.

If in doubt, or severe operating conditions apply, please contact our Technical Support Team for recommendations.

## Guide bush details

The positioning of guide bushes on the pressure side of the gland housing ensures their correct lubrication. Close fitting bushes are desirable to protect the rod or gland seals from the action of eccentric rods.

Close fitting bushes, however, can cause fluid starvation to the seal housing; or in certain conditions, an intensification of fluid pressure can occur. These potential hazards can easily be avoided by providing pressure relief through the bush to the adjacent seal housing.

## Rod/ram hardness

Our hydraulic seals tolerate many levels of counterface hardness, but for optimum life — particularly at higher pressures — we recommend a minimum of 300 Brinell (31 Rockwell C).

## Extrusion clearance

Recommended extrusion clearances: mm (inch)					
Shaft $\varnothing$ – f8 <sup>*1</sup> ; Cylinder $\varnothing$ – H9 <sup>*1</sup>		Diametral tolerances		Maximum diametral extrusion clearance: E	
Above	Up to and including	Shaft / Gland applications Follower bore (Inside) $\varnothing$ <sup>*2</sup>	Piston / Cylinder applications Piston (outside) $\varnothing$ <sup>*3- *4</sup>	0 - 20 MPa (0 - 2900 psi)	20 - 40 MPa (2900 - 5800 psi)
10.00 (0.39)	18.00 (0.71)	+0.086 / +0.043 (+0.0034 / +0.0017)	N/A	0.21 (0.008)	0.14 (0.006)
18.00 (0.71)	30.00 (1.18)	+0.104 / +0.052 (+0.0041 / +0.0020)	-0.104 / -0.052 (-0.0041 / -0.0020)	0.24 (0.009)	0.16 (0.006)
30.00 (1.18)	50.00 (1.97)	+0.124 / +0.062 (+0.0049 / +0.0024)	-0.124 / -0.062 (-0.0049 / -0.0024)	0.30 (0.012)	0.20 (0.008)
50.00 (1.97)	80.00 (3.15)	+0.148 / +0.074 (+0.0058 / +0.0029)	-0.148 / -0.074 (-0.0058 / -0.0029)	0.35 (0.014)	0.23 (0.009)
80.00 (3.15)	120.00 (4.72)	+0.174 / +0.087 (+0.0069 / +0.0034)	-0.174 / -0.087 (-0.0069 / -0.0034)	0.48 (0.019)	0.32 (0.013)
120.00 (4.72)	180.00 (7.09)	+0.200 / +0.100 (+0.0079 / +0.0039)	-0.200 / -0.100 (-0.0079 / -0.0039)	0.52 (0.021)	0.35 (0.014)
180.00 (7.09)	250.00 (8.84)	+0.230 / +0.115 (+0.0091 / +0.0045)	-0.230 / -0.115 (-0.0091 / -0.0045)	0.56 (0.022)	0.37 (0.015)
250.00 (8.84)	315.00 (12.40)	+0.260 / +0.130 (+0.0102 / +0.0051)	-0.260 / -0.130 (-0.0102 / -0.0051)	0.60 (0.024)	0.41 (0.016)
315.00 (12.40)	400.00 (15.75)	+0.280 / +0.140 (+0.0110 / +0.0055)	-0.280 / -0.140 (-0.0110 / -0.0055)	0.70 (0.028)	0.46 (0.018)
400.00 (15.75)	500.00 (19.69)	+0.310 / +0.155 (+0.0122 / +0.0061)	-0.310 / -0.155 (-0.0122 / -0.0061)	0.75 (0.030)	0.50 (0.020)

### Notes

<sup>\*1</sup> Tolerances based on BS EN ISO 286-1 and BS EN ISO 286-2.

<sup>\*2</sup> Tolerances based on BS EN ISO 286-1 and BS EN ISO 286-2, using plus H9 maximum as the minimum follower bore  $\varnothing$  and then plus another H9 maximum to provide the maximum follower bore  $\varnothing$ .

<sup>\*3</sup> Tolerances based on BS EN ISO 286-1 and BS EN ISO 286-2, using minus H9 maximum as the maximum follower outside  $\varnothing$  and then minus another H9 maximum to provide the minimum follower outside  $\varnothing$ .

<sup>\*4</sup> When using these clearance tolerances careful consideration must be given the effects of cylinder dilation due to pressure fluctuations.

## Extrusion clearance

The control of extrusion clearances between the gland follower and rod is of vital importance. The gap between the rod and the inside of gland follower must be as small as possible, but should not be smaller than guidance fit allows. This is achieved by ensuring a very close fit between the outside of the gland follower and the housing bore.

The fit between adjacent housing components should be kept to a minimum. See table above for extrusion clearances for an H9/f8 guidance fit at neck bush where arduous conditions apply.

An equivalent level of fit between piston head and cylinder bore is also recommended.

**Maximum diametral extrusion clearance E. Shaft/follower bore and cylinder bore/piston at maximum eccentricity (touching).**

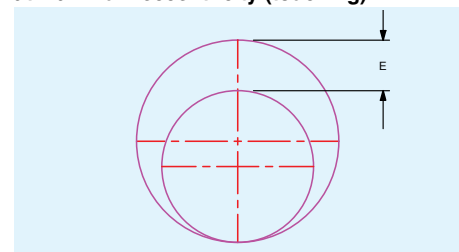

**Radial extrusion clearance E/2. Shaft/follower bore and cylinder bore/piston concentric.**

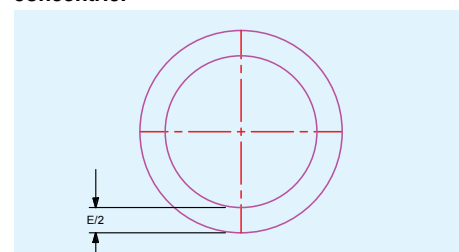

# Machining information

## Surface roughness values for piston & rod housings

### Based on BS ISO 5597

The surface roughness of the housing surfaces in contact with our sealing products, both dynamic and static, has a significant impact on their life and performance.

### Dynamic and static surfaces

Unless otherwise agreed between the equipment manufacturer and James Walker, all relevant roughness values should be in accordance with those shown in the table (*right*). The exception being when different values are specifically stated in individual seal requirements.

For some seal designs (eg, PTFE seals) a minimum roughness of 0.1µm Ra can be required for the dynamic sealing surface — otherwise the surface can be too smooth to provide adequate lubrication for the seal.

In addition, exceptional service conditions can necessitate other grades of surface roughness. In such cases, please consult our Technical Support Team.

It is important to ensure that all surfaces against which the seal operates should be free from chatter marks and scores along the operating axis of the seal.

## Surface roughness details

Radial depth of seal housing S (mm)	Contact surface roughness values (Micrometres unless otherwise specified) <sup>a) b) c)</sup>				Minimum required measuring length (mm) (5 times single measuring length plus 2 times cut off)
	Groove side surfaces A <sup>a)</sup>	Static pressure mating surface B <sup>b)</sup>	Dynamic pressure mating surface C <sup>c)</sup>	Lead-in/on chamfer surface D	
< 7.5	Ra 4 - 1.6 Rz 4 - 6.3	Ra 1.6 Rz 6.3	Ra 0.4 Rz 1.6	Ra 4 or Rz 16 visual inspection	5.6
≥ 7.5	Ra 1.6 Rz 6.3				

Unless otherwise agreed, the material ratio **Rmr** of the housing surfaces that are in mating contact with the product, should be between 50% and 80% at a profile section level **Rdc**, of 25% of **Rz**, from a reference level of 0.5% material ratio **C<sub>0</sub>**, (see BS EN ISO 4287).

Where surface roughness measurements are taken, it is recommended that instruments complying with BS EN ISO 3274, including an electric wave filter, be used.

### Table notes:

- <sup>a)</sup> Indication of surface roughness taken from BS EN ISO 1302.
- <sup>b)</sup> See BS EN ISO 13715 for design of edges and undefined shapes.
- <sup>c)</sup> Visual surface imperfections are not allowed on surfaces B and C (see BS EN ISO 8785).

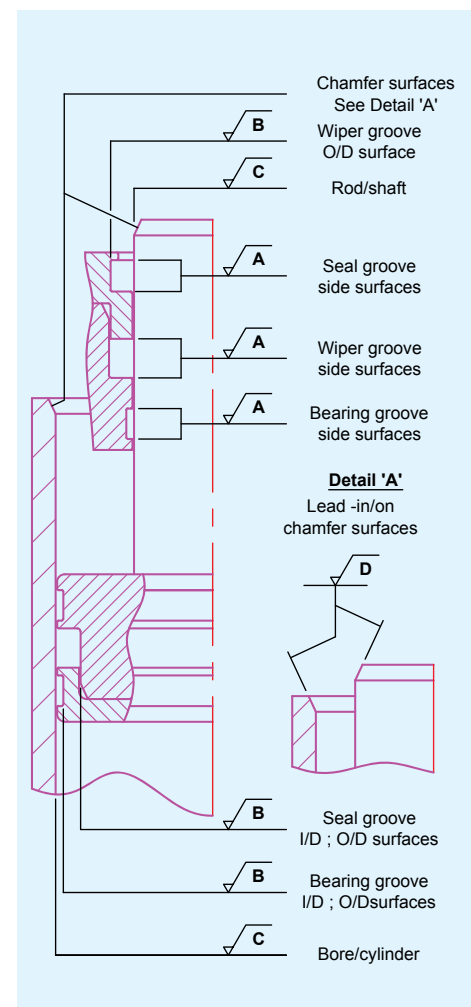

# Appendix A Chevron® preferred housing designs

## Design dimensional nomenclature

### Shaft/gland housing arrangement

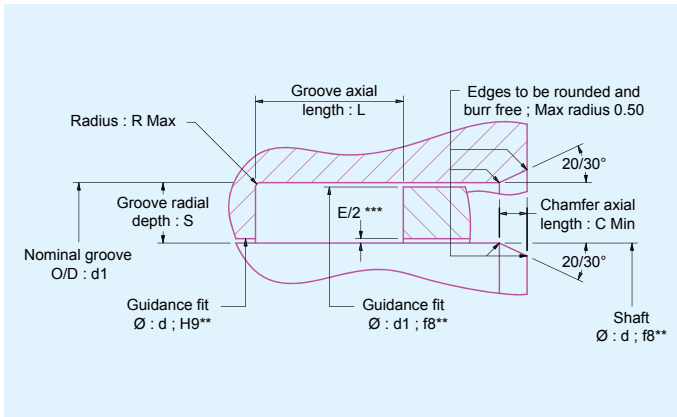

### Piston/cylinder housing arrangement

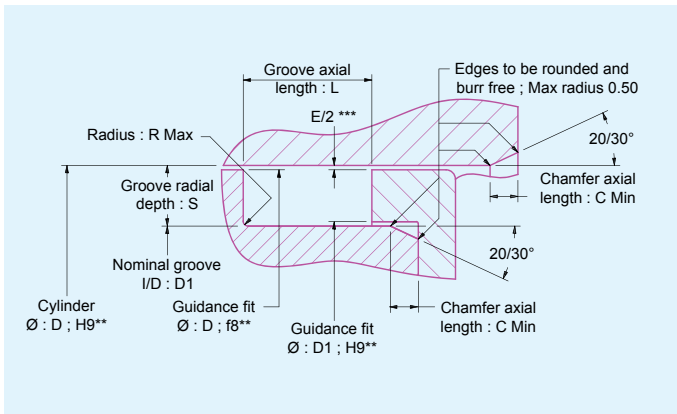

### Notes

- 1) For existing applications, please first check our *Hydraulic sealing products — Size charts* (see page 83).
- 2) For new applications housing dimensions are to be based on BS ISO 5597 — Long (L3) axial length series housings: See Appendix W.
- 3) E/2 \*\*\*: Radial clearances and extrusion gaps (parts concentric): See *Machining information* section.
- 4) Surface roughness and finish requirements: See *Machining information* section.
- 5) \*\* Tolerances in accordance with BS EN ISO 286 -1 and BS EN ISO 286 -2: See Appendix V.

## Chevron® preferred housing dimensions

Shaft Ø; d; f8 <sup>1)</sup>		Cylinder Ø; D; H9 <sup>1)</sup>		Housing		
Above	Up to & including	Above	Up to & including	Radial depth S	Axial length L	
					Nominal	Tolerance
Metric sizes (mm)						
6.00	8.00	N/A	N/A	4.00	14.50	+0.25 -0
8.00	25.00	20.00	40.00	5.00	16.00	
25.00	50.00	40.00	66.00	7.50	25.00	
50.00	90.00	66.00	110.00	10.00	32.00	
90.0	150.00	110.00	175.00	12.50	40.00	
150.00	300.00	175.00	330.00	15.00	50.00	
300.00	500.00	330.00	540.00	20.00	63.00	
500.00	900.00	540.00	940.00		73.00	
900.00	>	940.00	>	25.00	95.00	
Inch sizes (inch)						
>	11/16	>	1 1/16	3/16	1/2	+0.010 -0
11/16	1	1 1/16	1 1/2	1/4	3/4	
1	2	1 1/2	2 5/8	5/16	1	
2	3 1/2	2 5/8	4 1/4	3/8	1 1/4	
3 1/2	6	4 1/4	7	1/2	1 3/4	
6	16	7	17 1/4	5/8	2	
16	24	17 1/4	25 1/2	3/4	2 7/8	
24	36	25 1/2	37 1/2		3 1/4	
36	>	37 1/2	>	1	3 3/4	

<sup>1)</sup> Tolerances in accordance with BS EN ISO 286-1 & BS EN ISO 286-2

# Appendix B Solosele G® preferred housing designs

## Design dimensional nomenclature

### Shaft/gland housing arrangement

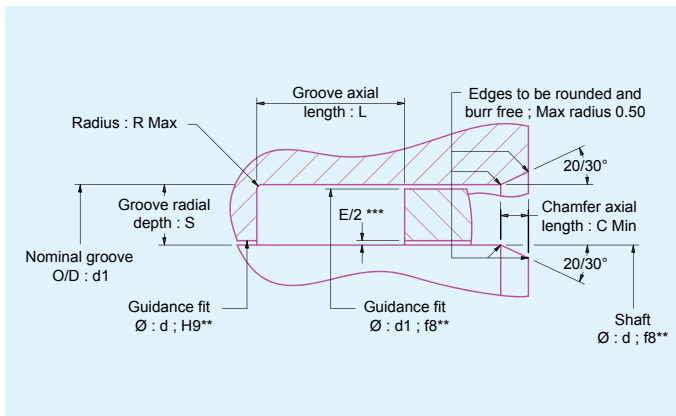

### Piston/cylinder housing arrangement

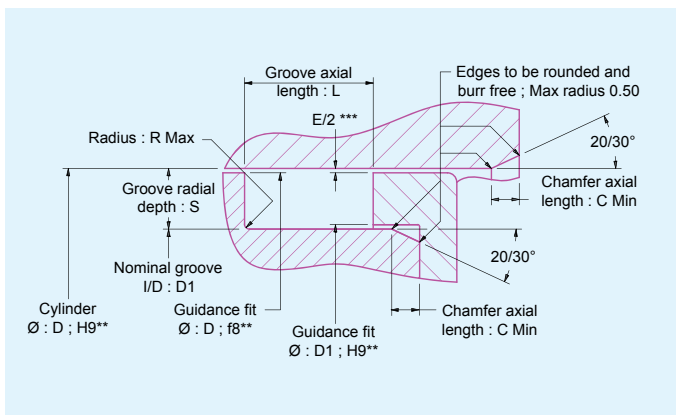

### Notes

- 1) For existing applications, please first check our *Hydraulic sealing products — Size charts* (see page 83).
- 2) For new applications housing dimensions are to be based on BS ISO 5597 — Short (L1) and Medium (L2) axial length series housings: See Appendix W.
- 3) E/2 \*\*\*: Radial clearances and extrusion gaps (parts concentric): See *Machining information* section.
- 4) Surface roughness and finish requirements: See *Machining information* section.
- 5) \*\* Tolerances in accordance with BS EN ISO 286 -1 and BS EN ISO 286 -2: See Appendix V.

### Solosele® G preferred housing dimensions

Shaft Ø; d; f8 <sup>1)</sup>		Cylinder Ø; D; H9 <sup>1)</sup>		Housing		
Above	Up to & including	Above	Up to & including	Radial depth S	Axial length L	
					Nominal	Tolerance
Metric sizes (mm)						
6.00	25.00	14.00	33.00	4.00	5.00	+0.25 -0
25.00	50.00	33.00	60.00	5.00	6.30	
50.00	90.00	60.00	105.00	7.50	9.50	
90.00	150.00	105.00	170.00	10.00	12.50	
150.00	200.00	170.00	200.00	12.50	16.00	
200.00	300.00	200.00	330.00	15.00	20.00	
300.00	500.00	330.00	540.00	20.00	25.00	
500.00	>	540.00	>		25.00	
Inch sizes (inch)						
1/4	1	5/8	1 3/8	3/16	1/4	+0.010 -0
1	2	1 3/8	2 1/2	1/4	5/16	
2	3 1/2	2 1/2	4 1/8	5/16	3/8	
3 1/2	5 1/2	4 1/8	6 1/4	3/8	15/32	
5 1/2	8	6 1/4	9	1/2	5/8	
8	11	9	12 1/4	5/8	25/32	
11	14	12 1/4	15 1/2	3/4	1	
14	>	15 1/2	>	1	1 1/4	

<sup>1)</sup> Tolerances in accordance with BS EN ISO 286-1 & BS EN ISO 286-2

# Appendix C

## Twinset preferred housing designs

### Design dimensional nomenclature

#### Shaft/gland housing arrangement

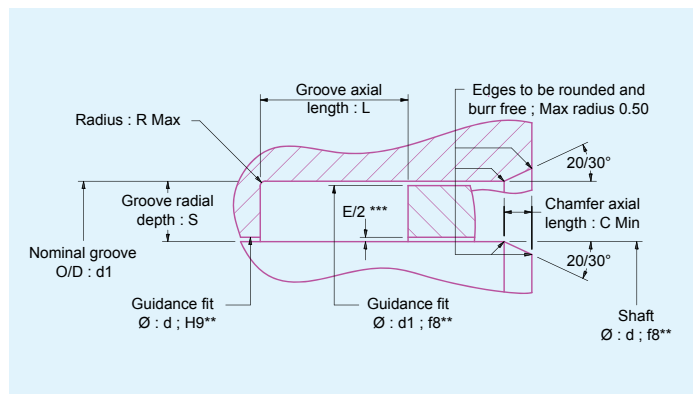

#### Piston/cylinder housing arrangement

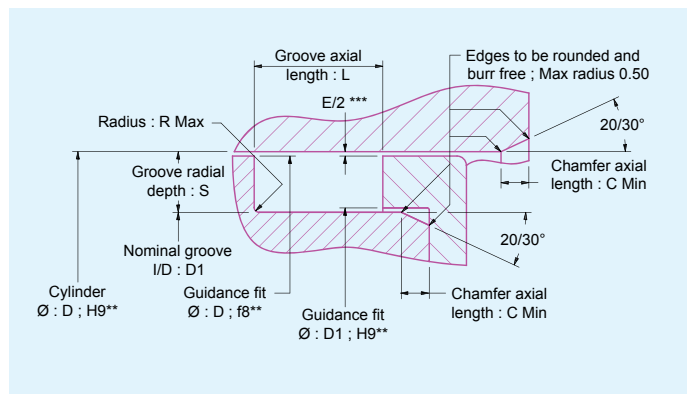

**Notes**

- 1) For existing applications, please first check our *Hydraulic sealing products — Size charts* (see page 83).
- 2) For new applications housing dimensions are to be based on BS ISO 5597 — Long (L3) axial length series housings: See Appendix W.
- 3) E/2 \*\*\*: Radial clearances and extrusion gaps (parts concentric): See *Machining information* section.
- 4) Surface roughness and finish requirements: See *Machining information* section.
- 5) \*\* Tolerances in accordance with BS EN ISO 286 -1 and BS EN ISO 286 -2: See Appendix V.

#### Twinset preferred housing dimensions

Shaft Ø; d; f8 <sup>1)</sup>		Cylinder Ø; D; H9 <sup>1)</sup>		Housing				
Above	Up to & including	Above	Up to & including	Radial depth S	Axial length L		Minimum chamfer length C Min	Groove base rad R Max
					Nominal	Tolerance		
Metric sizes (mm)								
>	15.00	>	25.00	5.00	11.00	+ 0.25, - 0	2.50	0.30
15.00	25.00	25.00	38.00	6.50	14.00		4.00	0.40
25.00	50.00	38.00	50.00	8.00	30.00		5.00	0.60
50.00	90.00	50.00	90.00	10.00	24.00		5.00	0.80
90.00	150.00	90.00	150.00	12.50	32.00		6.50	
150.00	400.00	150.00	400.00	15.00	38.00		7.50	1.00
400.00	500.00	400.00	500.00	20.00	47.00		10.00	
400.00	900.00	400.00	900.00					
900.00	>	900.00	>	25.00	50.00	+ 0.40, - 0		
Inch sizes (inch)								
>	1 1/16	>	1 1/8	3/16	7/16	+ 0.010, - 0	0.100	0.015
1 1/16	1	1 1/8	1 1/2	1/4	9/16		0.160	0.020
1	2	1 1/2	2 5/8	5/16	3/4		0.200	0.030
2	3 1/2	2 5/8	4 1/4	3/8	15/16		0.260	0.035
3 1/2	6	4 1/4	7	1/2	1 1/4			
6	16	7	17 1/4	5/8	1 1/2		0.300	0.040
16	20	17 1/4	20	3/4	1 3/4		0.400	
16	36	17 1/4	37 1/2					
36	>	37 1/2	>	1	2	+ 0.015, - 0		

<sup>1)</sup> Tolerances in accordance with BS EN ISO 286-1 and BS EN ISO 286-2



# Appendix D Lionsele® LF preferred housing designs

## Design dimensional nomenclature

### Shaft/gland housing arrangement

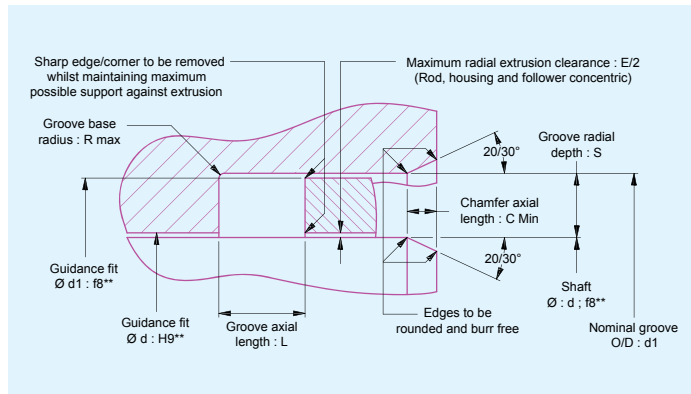

### Piston/cylinder housing arrangement

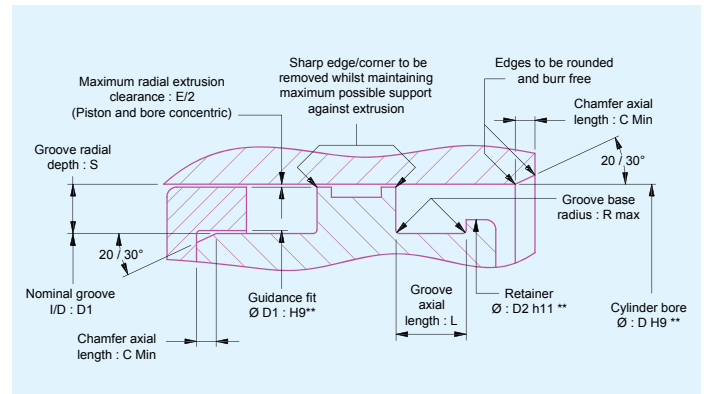

#### Notes

- 1) For existing and new applications see JW preferred housing dimensions.
- 2) E/2\*\*; Radial clearances and extrusion gaps (parts concentric): see Preferred housing dimensions.
- 3) Surface roughness and finish requirements: See *Machining information* section.
- 4) \*\* Tolerances in accordance with BS EN ISO 286 -1 and BS EN ISO 286 -2.

### Lionsele® LF preferred housing dimensions

#### Cylinder/piston housings (mm)

Cylinder Ø D H9 **		Retainer Ø D2 h11 **	Housing groove			Maximum extrusion gap E		Chamfer length C Min
Above	Up to		Radial depth S	Axial length L	Base radius Rmax	0 - 20 MPa	20 - 40 MPa	
7.00	12.00	D1 = (ØD - 1.5 x S)	1.52 / 1.57	2.30 / 2.50	0.30	0.20	0.13	1.50
12.10	20.00		2.31 / 2.39	3.50 / 3.70		0.26	0.13	1.50
20.10	45.00		3.10 / 3.18	4.70 / 4.90		0.30	0.15	2.00
20.00	110.00		4.67 / 4.78	7.00 / 7.20		0.36	0.18	2.50
50.00	700.00		6.22 / 6.35	9.40 / 9.60	0.40	0.40	0.20	4.00

#### Rod/shaft gland housings (mm)

Rod Ø f8 d **		Housing groove			Maximum extrusion gap E		Chamfer length C Min
Above	Up to	Radial depth S	Axial length L	Base radius Rmax	0 - 20 MPa	20 - 40 MPa	
5.00	9.90	1.52 / 1.57	2.30 / 2.50	0.30	0.20	0.13	1.50
10.00	19.90	2.31 / 2.39	3.50 / 3.70		0.26	0.13	1.50
20.00	40.00	3.10 / 3.18	4.70 / 4.90		0.30	0.15	2.00
20.00	120.00	4.67 / 4.78	7.00 / 7.20		0.36	0.18	2.50
40.00	660.00	6.22 / 6.35	9.40 / 9.60	0.40	0.40	0.20	4.00

\*\* Tolerances in accordance with BS EN ISO 286-1 and BS EN ISO 286-2

#### Surface finish requirements

The recommended values for surface finish are as shown below. Surface finish values better than 0.1µm Ra should not be used.

Application	Surface finish - BS 1134 : Part 1
All cryogenics. Dynamic duties with light gases (H, He, etc)	0.1 to 0.2 µm (4 to 8 µin) Ra
Static duties with light gases (H, He, etc). Dynamic duties with other media	0.1 to 0.3 µm (4 to 12 µin) Ra
Static duties with other gases. Static duties with gasoline, diesel and aviation fuels	0.1 to 0.8 µm (4 to 32 µin) Ra
General static duties - Water and aqueous solutions, hydraulic fluids, oils and other liquids	0.1 to 1.6 µm (4 to 64 µin) Ra

# Appendix E

## Lionsele® U1, U2 & U3 preferred housing designs

### Design dimensional nomenclature

#### Lionsele® U1 and U2 shaft/gland housing arrangement

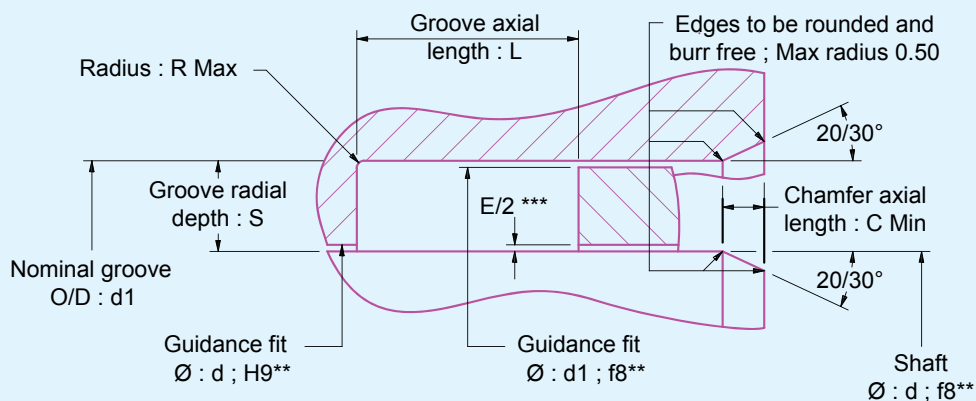

#### Lionsele® U1 and U3 piston/cylinder housing arrangement

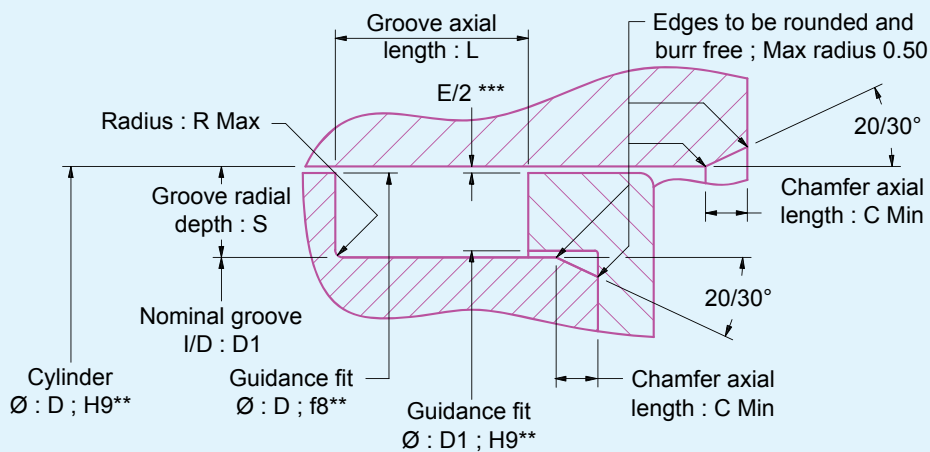

- Notes**
- 1) For existing and new applications housing dimensions are to be based on BS ISO 5597 — Short (L1) and Medium (L2) axial length series, and BS ISO 6020-2 housings. See Appendix W.
  - 2) E/2 \*\*\*: Radial clearances and extrusion gaps (parts concentric): See *Machining information* section.
  - 3) Surface roughness and finish requirements: See *Machining information* section.
  - 4) \*\* Tolerances in accordance with BS EN ISO 286 -1 and BS EN ISO 286 -2: See Appendix V.

# Appendix F

## Lofilm® preferred housing designs

### Design dimensional nomenclature

#### Shaft/gland housing arrangement

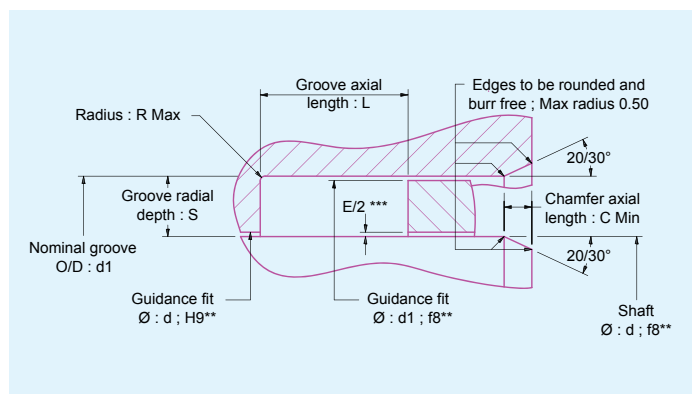

#### Notes

- 1) For existing applications, please first check our *Hydraulic sealing products — Size charts* (see page 83).
- 2) For new applications housing dimensions are to be based on BS ISO 5597 — Long (L3) axial length series housings: See Appendix W.
- 3) E/2 \*\*\*: Radial clearances and extrusion gaps (parts concentric): See *Machining information* section.
- 4) Surface roughness and finish requirements: See *Machining information* section.
- 5) \*\* Tolerances in accordance with BS EN ISO 286 -1 and BS EN ISO 286 -2: See Appendix V.

#### Lofilm® preferred housing dimensions

Shaft Ø: d; f8 <sup>1)</sup>		Housing		
Above	Up-to and including	Radial depth S	Axial length L	
			Nominal	Tolerance
Metric sizes (mm)				
6.00	8.00	4.00	14.50	+ 0.25, - 0
8.00	25.00	5.00	16.00	
25.00	50.00	7.50	25.00	
50.00	90.00	10.00	32.00	
90.00	150.00	12.50	40.00	
150.00	300.00	15.00	50.00	
300.00	500.00	20.00	63.00	
500.00	900.00		73.00	
900.00	>	25.00	95.00	
Inch sizes (inch)				
>	11/16	3/16	1/2	+ 0.010, - 0
11/16	1	1/4	3/4	
1	2	5/16	1	
2	3 1/2	3/8	1 1/4	
3 1/2	6	1/2	1 3/4	
6	16	5/8	2	
16	24	3/4	2 7/8	
24	36		3 1/4	
36	>		1	

<sup>1)</sup> Tolerances in accordance with BS EN ISO 286-1 and BS EN ISO 286-2

# Appendix G Lion® Expanding preferred housing designs

## Design dimensional nomenclature

### Shaft/gland housing arrangement

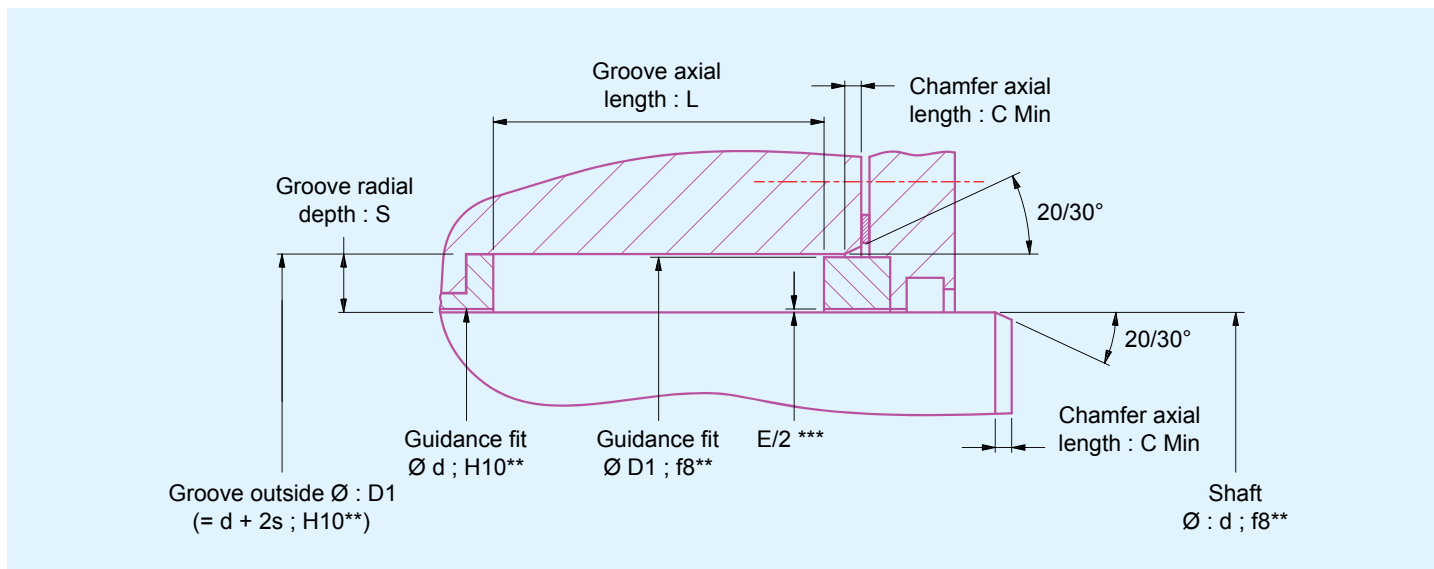

**Notes**

- 1) For existing and new applications see JW preferred housing dimensions.
- 2) E/2 \*\*\*: Radial extrusion clearance: See *Machining information* section.
- 3) Surface roughness and finish requirements: See *Machining information* section.
- 4) \*\* Tolerances in accordance with BS EN ISO 286 -1 and BS EN ISO 286-2: See Appendix V.

### Lion® Expanding preferred housing dimensions

Shaft $\text{Ø} ; d ; e8^{**}$		Nominal radial depth S	Nominal set / housing depth L		Chamfer length C Min
Above	Up to & including		Up to 35MPa	Above 35 and up to 62MPa	
Metric sizes (mm)					
300.00	600.00	20.00	115.00	148.00	10.00
600.00	1200.00	25.00	145.00	183.00	
1200.00		30.00	175.00	224.00	
Inch sizes (Inch)					
12.000	18.000	0.750	4.500	5.500	0.375
18.000	24.000	0.875	5.000	6.375	
24.000		1.000	5.750	7.750	

\*\* Tolerances in accordance with BS EN ISO 286-1 and BS EN ISO 286-2

Appendix G

# Appendix H

## Lofilm<sup>®</sup> HD preferred housing designs

### Design dimensional nomenclature

#### Shaft/gland housing arrangement

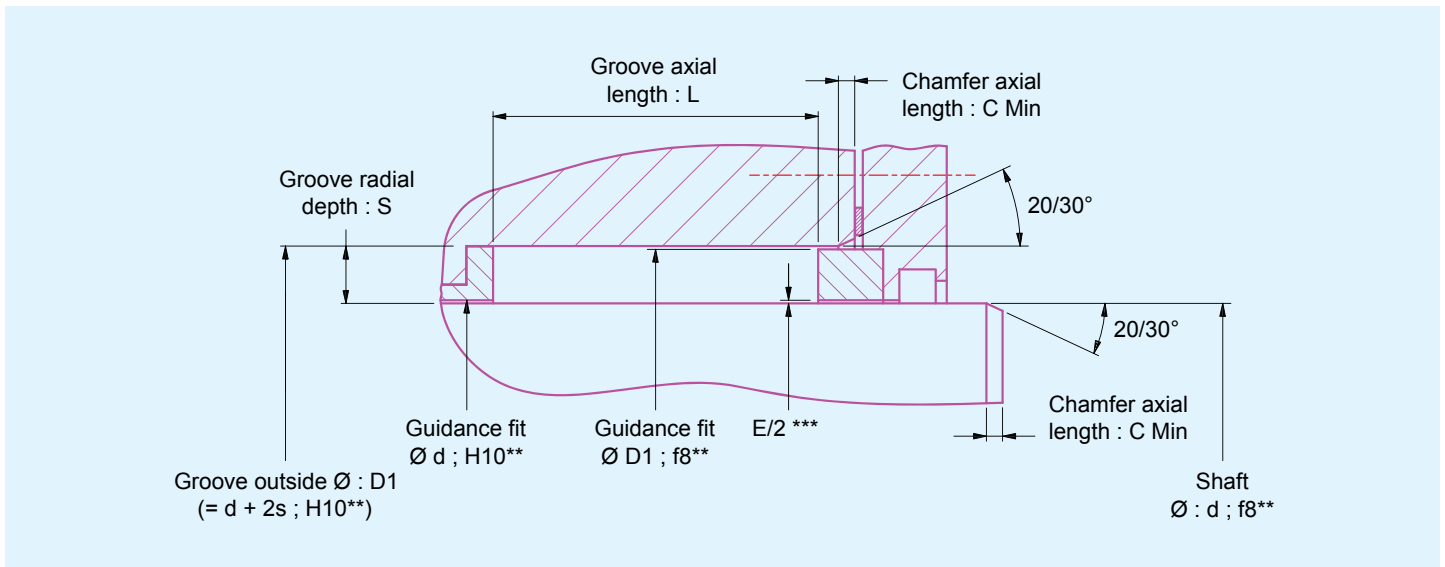

#### Notes

- 1) For existing and new applications see JW preferred housing dimensions.
- 2) E/2<sup>\*\*\*</sup>: Radial extrusion clearance: See *Machining information* section.
- 3) Surface roughness and finish requirements: See *Machining information* section.
- 4) \*\* Tolerances in accordance with BS EN ISO 286 -1 and BS EN ISO 286-2: See Appendix V.

#### Lofilm<sup>®</sup> HD preferred housing dimensions

Shaft $\varnothing$ ; d; e8 <sup>**</sup>		Nominal radial depth S	Housing length L	Chamfer length C Min
Above	Up to & including			
Metric sizes (mm)				
500.00	1000.00	25.00	112.50	10.00
1000.00		30.00	135.00	12.50
Inch sizes (inch)				
19.625	24.000	0.875	3.313	0.375
24.000		1.000	4.500	0.500

\*\* Tolerances in accordance with BS EN ISO 286-1 and BS EN ISO 286-2

# Appendix I Lionsele® G preferred housing designs

## Design dimensional nomenclature

### Shaft/gland housing arrangement

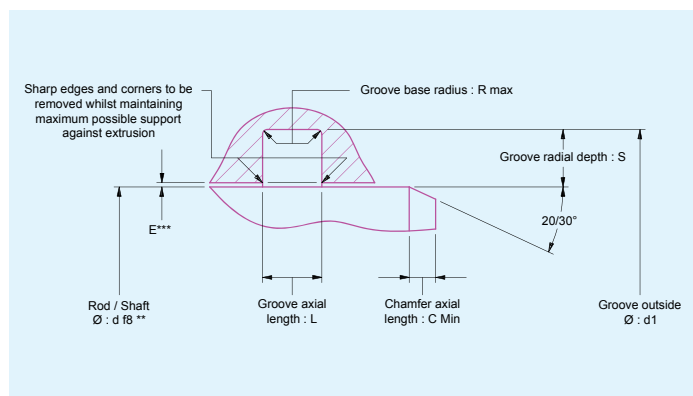

#### Notes

- 1) For existing applications see JW preferred housing dimensions.
- 2) For new applications housing dimensions are to be based on BS ISO 7425-2; Tables 1 and 2.
- 3) E\*\*\*: Radial clearances and extrusion gaps (parts concentric): See *Machining Information* section.
- 4) Surface roughness and finish requirements: See *Machining information* section.
- 5) \*\* Tolerances in accordance with BS EN ISO 286 -1 and BS EN ISO 286 -2: See Appendix V.

### Lionsele® G preferred housing dimensions

Shaft Ø; d; f8** (mm)		Housing groove (mm)		Chamfer length C min (mm)
Above	Up to & including	Nominal radial depth S	Nominal axial length L +0.20 / +0	
6.00	14.90	2.50	2.20	1.50
14.90	24.90	3.75	3.20	2.00
24.90	59.90	5.50	4.20	2.50
59.90	199.90	7.75	6.30	4.00
199.90	>	10.50	8.30	5.00

\*\* Tolerances in accordance with BS EN ISO 286-1 and BS EN ISO 286-2

### Dimensions and tolerances for rod seal housings

Based on BS ISO 7425-2 Tables 1 and 2

Rod <sup>1)</sup> Ø; d; f8 <sup>2)</sup> (mm)	Groove dimensions (mm)				Chamfer length C Min (mm)
	Outside Ø d1	Tolerance	Nominal radial depth S	Axial length L +0.25 / +0	
6.00	11.00	H9 **	2.50	2.20	1.50
8.00	13.00				
10.00	15.00				
12.00	17.00		3.75	3.20	2.00
	19.50				
14.00	19.00		2.50	2.20	1.50
	21.50				
16.00	23.50		3.75	3.20	2.00
18.00	25.50				
20.00	27.50		5.50	4.20	2.50
	31.00				
22.00	29.50		3.75	3.20	2.00
	33.00				
25.00	32.50		5.50	4.20	2.50
	36.00				
28.00	39.00		3.75	3.20	2.00
32.00	43.00				
36.00	47.00	5.50	4.20	2.50	
40.00	51.00				
45.00	56.00	7.75	6.30	4.00	
50.00	61.00				
56.00	67.00	5.50	4.20	2.50	
	71.50				
63.00	74.00	7.75	6.30	4.00	
	78.50				
70.00	85.50	10.50	8.10	5.00	
80.00	95.50				
90.00	105.50	7.75	6.30	4.00	
100.00	115.50				
110.00	125.50	10.50	8.10	5.00	
125.00	140.50				
140.00	155.50	7.75	6.30	4.00	
160.00	175.50				
180.00	181.00	10.50	8.10	5.00	
	195.50				
200.00	201.00	7.75	6.30	4.00	
	221.00				
220.00	241.00	10.50	8.10	5.00	
250.00	271.00				
280.00	304.50	12.25	8.10	6.50	
320.00	344.50				
360.00	384.50				

<sup>1)</sup> Bore diameters in accordance with ISO 3320

<sup>2)</sup> See BS EN ISO 286-1 and BS EN ISO 286 -2

# Appendix J

## Lionsele® SP preferred housing designs

### Design dimensional nomenclature

#### Piston housing arrangement

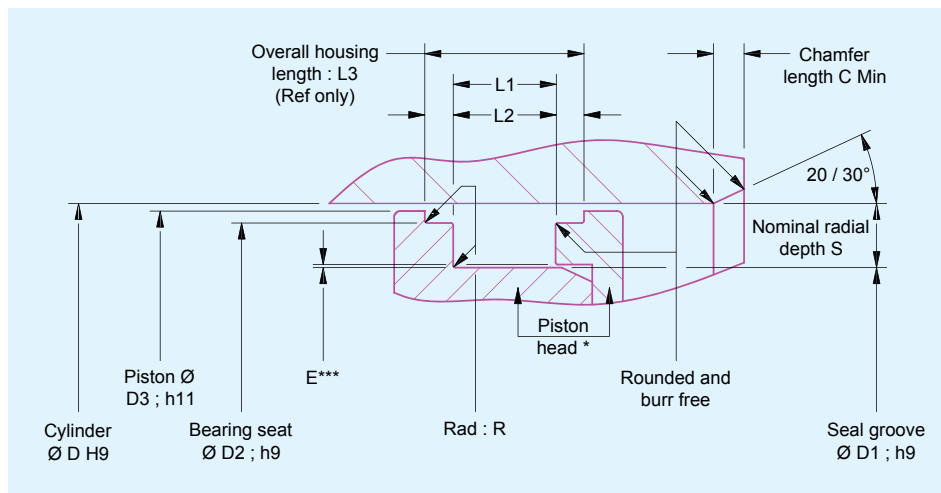

#### Notes

- 1) For existing and new applications housing dimensions are to be based on BS ISO 6547.
- 2) Piston head \*: Design can be multi-component assembly as shown or single machined component.
- 3) E\*\*\*: Radial clearances and extrusion gaps (parts concentric): See *Machining Information* section.
- 4) Surface roughness and finish requirements: See *Machining information* section.
- 5) \*\* Tolerances in accordance with BS EN ISO 286 -1 and BS EN ISO 286 -2: See Appendix V.

#### Lionsele® SP piston seal housing dimensions

Based on BS ISO 6547

Bore Ø D H9 *** (mm)	Nominal radial section S (mm)	Seal groove Ø D1 h9 ** (mm)	Seal groove length L1 + 0.35 / + 0.10 (mm)	Bearing ring length L2 + 0.10 / + 0 (mm)	Overall length (Ref only) L3 (mm)	Bearing ring Ø D2 h9 ** (mm)	Piston Ø D3 h11 ** (mm)	Base radius Rmax (mm)	Chamfer C Min (mm)	
25.00	4.00	17.00	10.00	4.00	18.00	22.00	24.00	0.40	2.00	
	5.00	15.00	12.50		20.50				2.50	
32.00	4.00	24.00	10.00	4.00	18.00	29.00	31.00		2.00	
	5.00	22.00	12.50		20.50				2.50	
40.00	4.00	32.00	10.00	4.00	18.00	37.00	39.00		2.00	
	5.00	30.00	12.50		20.50				2.50	
50.00	5.00	40.00	12.50	4.00	20.50	47.00	49.00		2.50	
	7.50	35.00	20.00	5.00	30.00	46.00	48.50		4.00	
63.00	5.00	53.00	12.50	4.00	20.50	60.00	62.00		2.50	
	7.50	48.00	20.00	5.00	30.00	59.00	61.50		4.00	
80.00	7.50	65.00	20.00	5.00	30.00	76.00	78.50	0.40	4.00	
	10.00	60.00	25.00	6.30	37.60	75.00	78.00	0.80	5.00	
100.00	7.50	85.00	20.00	5.00	30.00	96.00	98.50	0.40	4.00	
	10.00	80.00	25.00	6.30	37.60	95.00	98.00	0.80	5.00	
125.00	10.00	105.00	25.00	6.30	37.60	120.00	123.00	0.80	5.00	
	12.50	100.00	32.00	10.00	52.00	119.00	123.00		6.50	
160.00	10.00	140.00	25.00	6.30	37.60	155.00	158.00		5.00	
	12.50	135.00	32.00	10.00	52.00	154.00	158.00		6.50	
200.00	15.00	170.00	36.00	12.50	61.00	192.00	197.00		7.50	
250.00		220.00				247.00				
320.00		290.00				317.00				
400.00		360.00				397.00				
500.00	20.00	460.00	50.00	16.00	82.00	492.00	497.00		1.20	10.00

<sup>1)</sup> See ISO 3320

<sup>2)</sup> Tolerance H11 on bore diameter may be used except when using smaller radial section seals for diameters of 25 to 160 mm inclusive

\*\* All tolerances in accordance with BS EN ISO 286-1 and BS EN ISO 286 -2

# Appendix K

## Lionsele® P preferred housing designs

### Design dimensional nomenclature

#### Piston housing arrangement

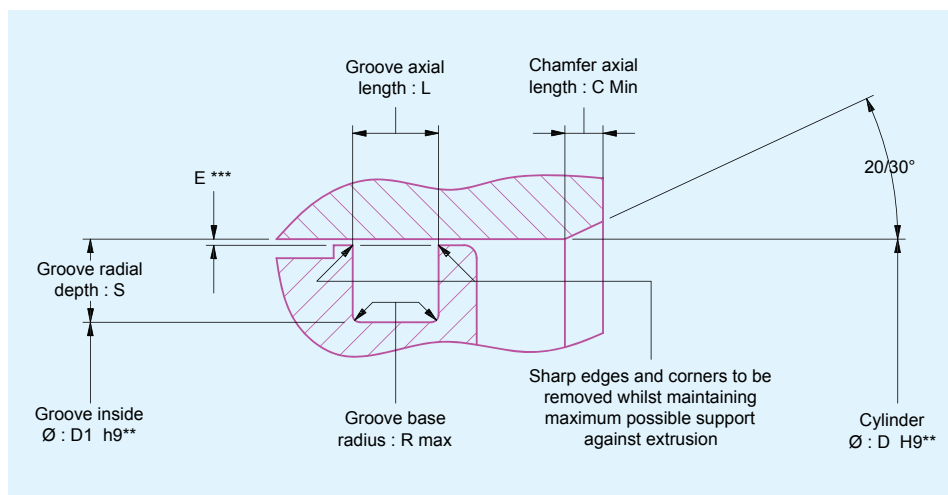

**Notes**

- 1) For existing applications, please first check our *Hydraulic sealing products — Size charts* (see page 83).
- 2) For new applications housing dimensions are to be based on BS ISO 7425-1; Tables 1 and 2.
- 3) E\*\*\*: Radial clearances and extrusion gaps (parts concentric): See *Machining Information* section.
- 4) Surface roughness and finish requirements: See *Machining Information* section.
- 5) \*\* Tolerances in accordance with BS EN ISO 286 -1 and BS EN ISO 286 -2: See Appendix V.

#### Lionsele® P preferred housing dimensions and tolerances

Based on BS ISO 7425 -1 Tables 1 and 2

Cylinder Ø H9** (mm)		Housing groove (mm)		Chamfer length C Min (mm)
Above	Up to and including	Radial depth (Section) S	Nominal Axial length L + 0.20 / + 0	
16.00	39.00	3.75	3.20	2.00
39.00	79.90	5.50	4.20	2.50
79.90	132.90	7.75	6.30	4.00
132.90	329.90	10.50	8.10	5.00
329.90	669.90	12.25	8.10	6.50
669.90	999.90	14.00	9.50	7.50
999.90	>	19.00	18.80	10.00

\*\* Tolerances in accordance with BS EN ISO 286-1 and BS EN ISO 286-2



# Appendix K

## Lionsele® P preferred housing designs

### Lionsele® P piston seal housings dimensions and tolerances

Based on BS ISO 7425 -1 Tables 1 and 2

Bore Ø <sup>1)</sup> D H9 ** (mm)	Radial depth S (mm)	Groove Ø d h9 ** (mm)	Groove axial length - L (mm)	Base radius Rmax (mm)	Chamfer length C Min (mm)
16.00	2.50	11.00	2.20 / 2.40	0.50	1.50
	3.75	8.50	3.20 / 3.40		2.00
20.00	2.50	15.00	2.20 / 2.40		1.50
	3.75	12.50	3.20 / 3.40		2.00
25.00	3.75	17.50	3.20 / 3.40		2.50
	5.50	14.00	4.20 / 4.40		3.00
	5.00	15.00	5.00 / 5.20		2.50
32.00	3.75	24.50	3.20 / 3.40		2.00
	5.50	21.00	4.20 / 4.40		2.50
	5.00	22.00	5.00 / 5.20		2.50
40.00	3.75	32.50	3.20 / 3.40		2.00
	5.50	29.00	4.20 / 4.40		2.50
	5.00	30.00	5.00 / 5.20		2.50
50.00	5.50	39.00	4.20 / 4.40		4.00
	7.75	34.50	6.30 / 6.50		4.00
63.00	7.50	35.00	7.50 / 7.70		2.50
	5.50	52.00	4.20 / 4.40		4.00
	7.75	47.50	6.30 / 6.50		4.00
80.00	7.50	48.00	7.50 / 7.70		2.50
	5.50	69.00	4.20 / 4.40		4.00
	7.75	64.50	6.30 / 6.50	5.00	
100.00	10.00	60.00	10.00 / 10.20	2.50	
	5.50	89.00	4.20 / 4.40	4.00	
	7.75	84.50	6.30 / 6.50	5.00	
125.00	10.00	80.00	10.00 / 10.20	4.00	
	7.75	109.50	6.30 / 6.50	5.00	
	10.50	104.00	8.10 / 8.30	4.00	
160.00	10.00	105.00	10.00 / 10.20	4.00	
	7.75	144.50	6.30 / 6.50	5.00	
	10.50	139.00	8.10 / 8.30	6.50	
200.00	12.50	135.00	12.50 / 12.70	4.00	
	7.75	184.50	6.30 / 6.50	5.00	
	10.50	179.00	8.10 / 8.30	6.50	
250.00	12.50	175.00	12.50 / 12.70	5.00	
	10.50	229.00	8.10 / 8.30	6.50	
	12.25	225.50	8.10 / 8.30	7.50	
320.00	15.00	220.00	15.00 / 15.20	5.00	
	10.50	299.00	8.10 / 8.30	6.50	
	12.25	295.50	8.10 / 8.30	7.50	
400.00	15.00	290.00	15.00 / 15.20	6.50	
	12.25	375.50	8.10 / 8.30	7.50	
	15.00	370.00	12.50 / 12.70	10.00	
500.00	20.00	360.00	20.00 / 20.20	6.50	
	12.25	475.50	8.10 / 8.30	7.50	
	15.00	470.00	12.50 / 12.70	10.00	
	20.00	460.00	20.00 / 20.20		

<sup>1)</sup> Bore diameters in accordance with ISO 3320

\*\* All tolerances in accordance with BS EN ISO 286-1 and BS EN ISO 286-2

# Appendix L

## Solosele® S preferred housing designs

### Design dimensional nomenclature

#### Piston housing arrangement

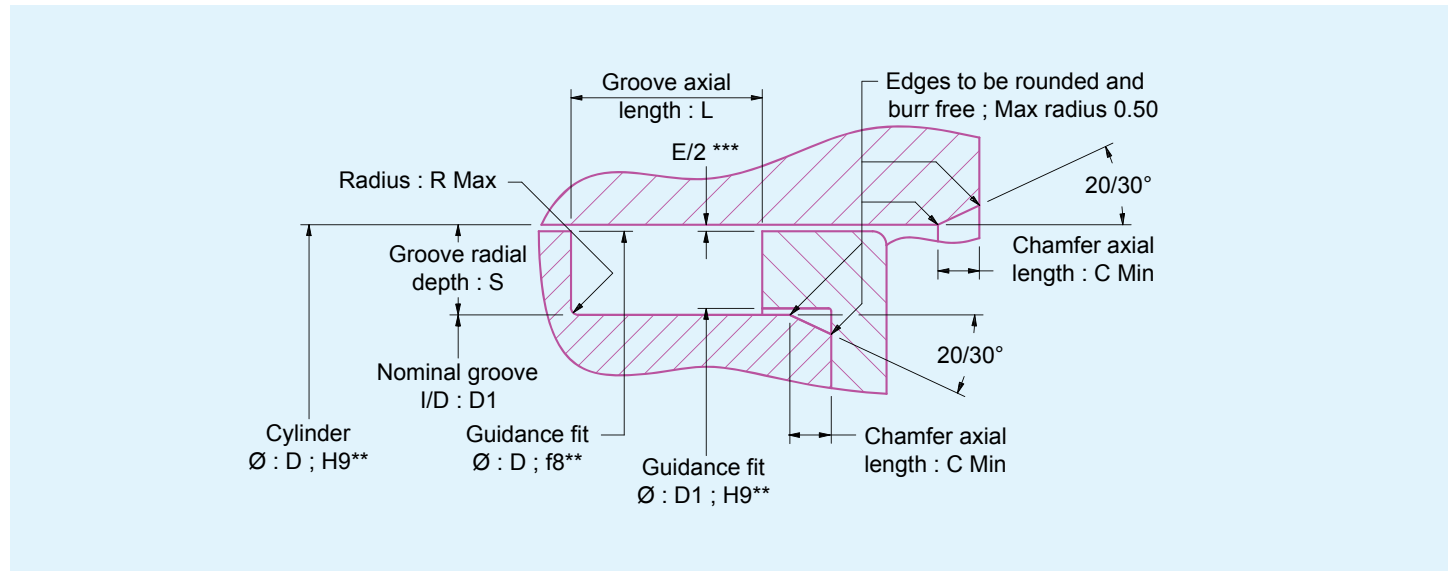

#### Notes

- 1) For existing and new applications housing dimensions are to be based on BS ISO 5597 — Medium (L2) axial length series housings: See Appendix W.
- 2) E/2 \*\*\*: Radial clearances and extrusion gaps (parts concentric): See *Machining information* section.
- 3) Surface roughness and finish requirements: See *Machining information* section.
- 4) \*\* Tolerances in accordance with BS EN ISO 286-1 and BS EN ISO 286-2: See Appendix V.

# Appendix M

## Solosele® SW preferred housing designs

### Design dimensional nomenclature

#### Shaft/gland housing arrangement

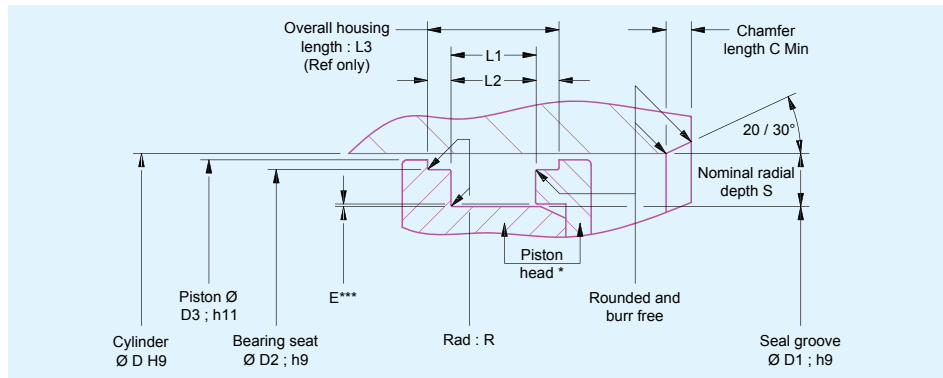

#### Notes

- 1) For existing and new applications housing dimensions see JW preferred housing dimensions.
- 2) Surface roughness and finish requirements: See *Machining information* section.
- 3) E\*\*\*: Radial clearances and extrusion gaps (parts concentric): See *Machining Information* section.
- 4) \*\* Tolerances in accordance with BS EN ISO 286-1 and BS EN ISO 286-2: See Appendix V.

#### Solosele® SW preferred housing dimensions

Housing diameters (mm)					Groove dimensions (mm)				Chamfer length C Min (mm)		
Cylinder Ø D H9**	Groove inside Ø D1 h10**	Piston Ø D2 h11**	Bearing seat Ø D3 h10**	Radial depth S	Overall length (Ref) L3	Seal seating length L1 +0.25/+0	Bearing seat length (Ref) L2 +0.1/+0	Base radius Rmax			
25.00	12.00	21.45	23.75	6.50	24.70	12.00	6.35	0.40	4.00		
30.00	17.00	26.45	28.95								
32.00	19.00	28.45	30.95								
40.00	24.00	35.40	43.65								
45.00	29.00	40.40	46.65	8.00	30.70	18.00		0.60	5.00		
48.00	32.00	43.35	46.65								
50.00	34.00	45.40	48.65								
55.00	39.00	50.40	53.65								
60.00	44.00	55.40	58.65	7.50	30.70	18.00				0.40	4.00
63.00	47.00	58.40	61.65								
65.00	50.00	60.40	63.65								
70.00	50.00	64.15	68.35								
75.00	55.00	69.15	73.35	10.00	34.70	22.00	0.60	5.00			
80.00	60.00	74.15	78.35								
83.00	63.00	77.15	81.35								
85.00	65.00	79.15	83.35								
90.00	70.00	84.15	88.35	12.50	34.70	22.00			0.80	6.50	
95.00	75.00	89.15	93.30								
100.00	75.00	93.15	98.00								
100.00	80.00	94.15	98.35								
105.00	80.00	98.10	103.00	10.00	34.70	22.00	0.60	5.00			
110.00	85.00	103.10	108.00								
115.00	90.00	108.10	113.00								
120.00	95.00	113.10	118.00								
125.00	100.00	117.80	123.00	12.50	34.70	22.00	0.80	6.50			
130.00	105.00	123.10	128.00								
135.00	110.00	128.00	133.00								
138.00	110.00	131.00	136.00								
140.00	120.00	134.05	138.35	14.00	37.70	25.00	0.80	7.50			
145.00	120.00	138.30	143.00								
150.00	125.00	143.00	148.00								
155.00	130.00	148.00	153.00								
160.00	130.00	153.00	158.00	15.00	37.70	25.00	0.80	7.50			

\*\* Tolerances in accordance with BS EN ISO 286-1 and BS EN ISO 286-2

# Appendix N — Composite seals (special duty) preferred housing designs

## Design dimensional nomenclature

### Housing arrangement

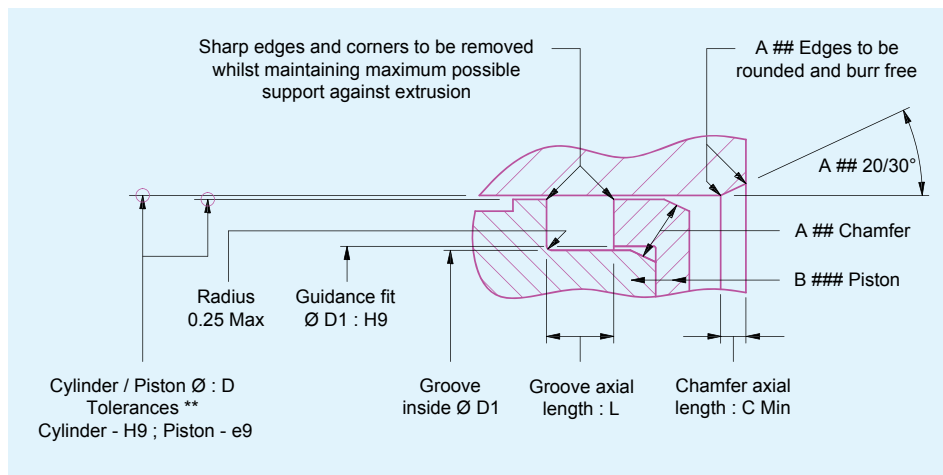

#### Notes

- 1) For existing and new applications see JW preferred housing dimensions.
- 2) A ## Chamfer: Details typical for all chamfers when used.
- 3) B ### Piston: Design can be multi-component assembly as shown or single machined component.
- 4) Surface roughness and finish requirements: See *Machining information* section.
- 5) \*\* Tolerances in accordance with BS EN ISO 286-1 and BS EN ISO 286-2: See Appendix V.

### Composite seals preferred housing dimensions (Standard seal range)

Cylinder Ø D H9**	Housing dimensions		Chamfer length C Min		
	Groove Ø D1	Axial length L			
Metric sizes (mm)					
25.00	11.96 / 12.10	7.40 / 7.60	4.00		
32.00	18.96 / 19.10				
40.00	26.96 / 27.10				
50.00	36.96 / 37.10				
63.00	46.96 / 47.12	8.90 / 9.10	5.00		
70.00	53.96 / 54.12				
75.00	58.96 / 59.12				
80.00	63.96 / 64.12				
90.00	73.98 / 74.12	10.90 / 11.10	5.00		
100.00	83.96 / 84.12				
110.00	89.92 / 90.14				
125.00	104.92 / 105.14				
140.00	119.92 / 120.14	10.90 / 11.10	5.00		
160.00	139.92 / 140.14				
Inch sizes (in)					
3/8	0.138 / 0.140			0.154 / 0.162	2.00
1/2	0.263 / 0.265				
5/8	0.389 / 0.391				
3/4	0.514 / 0.516				
7/8	0.639 / 0.641	0.291 / 0.299	4.00		
1	0.486 / 0.492				
1 1/4	0.737 / 0.743				
1 1/2	0.986 / 0.992				
1 3/4	1.237 / 1.243	0.350 / 0.358	5.00		
2	1.486 / 1.492				
2 1/2	1.869 / 1.875				
2 3/4	2.118 / 2.124				
3	2.367 / 2.375	0.350 / 0.358	5.00		
3 1/4	2.618 / 2.694				
3 1/2	2.869 / 2.875				
4	3.368 / 3.374				
4 1/2	3.710 / 3.718	0.429 / 0.437	5.00		
5	4.209 / 4.218				
5 1/2	4.709 / 4.718				
6	5.209 / 5.218				

### Composite seals preferred housing dimensions (Non-standard seals)

Cylinder Ø d H9**		Housing dimensions		Chamfer length C Min
Above	Up to & Inc.	Radial depth S	Axial length L	
Metric sizes (mm)				
-	22.00	2.98 / 3.02	3.90 / 4.10	2.50
22.00	50.00	6.45 / 6.52	7.40 / 7.60	4.00
50.00	100.00	7.94 / 8.02	8.90 / 9.10	5.00
100.00	400.00	9.93 / 10.13	10.90 / 11.10	5.00
400.00	900.00	12.86 / 13.14	14.40 / 14.60	7.50
900.00	1420.00	19.82 / 20.18	20.30 / 20.60	10.00
Inch sizes (in)				
-	7/8	0.117 / 0.119	0.154 / 0.162	2.00
7/8	2	0.254 / 0.257	0.291 / 0.299	4.00
2	4	0.312 / 0.315	0.350 / 0.358	5.00
4	16	0.391 / 0.399	0.429 / 0.437	5.00
16	35	0.506 / 0.517	0.567 / 0.575	7.50
35	56	0.780 / 0.794	0.799 / 0.811	10.00

\*\* Tolerances in accordance with BS EN ISO 286-1 & BS EN ISO 286-2

# Appendix O

## Lionsele® W1 wiper preferred housing designs

### Design dimensional nomenclature

#### Housing arrangement

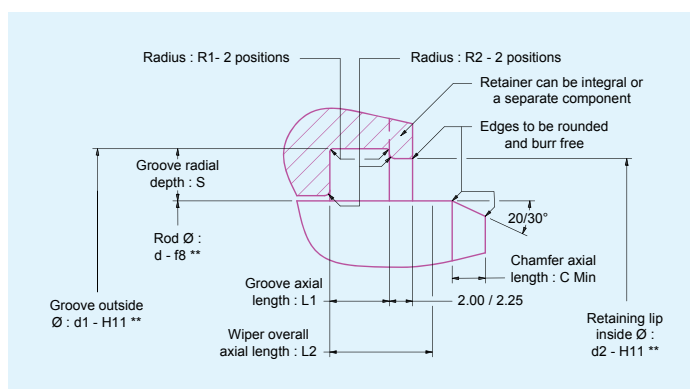

#### Notes

- 1) For existing and new applications housing dimensions are to be based on BS ISO 6195, Type A.
- 2) Surface roughness and finish requirements: See *Machining information* section.
- 3) \*\* Tolerances in accordance with BS EN ISO 286-1 and BS EN ISO 286-2: See Appendix V.

#### Lionsele® W1 housing dimensions for Type A wiper

Based on BS ISO 6195 Tables 1 and 7

Rod Ø <sup>A), B)</sup> (mm)	Radial depth (mm)	Outside Ø (mm)	Axial length (mm)	Retainer Ø (mm)	Radii Max (mm)		Wiper length (mm)	Chamfer length (mm)						
d	S	Ø d1 H11**	L1	Ø d2 H11**	R1	R2 <sup>C)</sup>	L2 Max	C Min						
4.00	4.00	12.00	5.00 + 0 ; + 0.20	9.50	0.30	0.50	8.00	2.00						
5.00		13.00		10.50										
6.00		14.00		11.50										
8.00		16.00		13.50										
10.00		18.00		15.50										
12.00		20.00		17.50										
14.00		22.00		19.50										
16.00		24.00		21.50										
18.00		26.00		23.50										
20.00		28.00		25.50										
22.00		30.00		27.50										
25.00		33.00		30.50										
28.00		36.00		33.50										
32.00		40.00		37.50										
36.00		44.00		41.50										
40.00	48.00	45.50												
45.00	53.00	50.50												
50.00	58.00	55.50												
56.00	66.00	63.00	6.30 + 0 ; + 0.20	0.40	10.00	2.50								
63.00	73.00	70.00												
70.00	80.00	77.00												
80.00	90.00	87.00												
90.00	100.00	97.00												
100.00	115.00	110.00					9.50 + 0 ; + 0.30	0.60	11.00	4.00				
110.00	125.00	120.00												
125.00	140.00	135.00												
140.00	155.00	150.00												
160.00	175.00	170.00												
180.00	195.00	190.00												
200.00	215.00	210.00												
220.00	240.00	233.50									12.50 + 0 ; + 0.30	0.80	18.00	5.00
250.00	270.00	263.50												
280.00	300.00	293.50												
320.00	340.00	333.50												
360.00	380.00	373.50												

<sup>A)</sup> See ISO 3320 and BS ISO 5597

<sup>B)</sup> One-piece housings can be used with rod diameters greater than 14mm

<sup>C)</sup> These specific dimensions permit the use of tools conforming to ISO 883 / BS 4193-2

# Appendix P

## Lionsele® W2 wiper preferred housing designs

### Design dimensional nomenclature

#### Housing arrangement

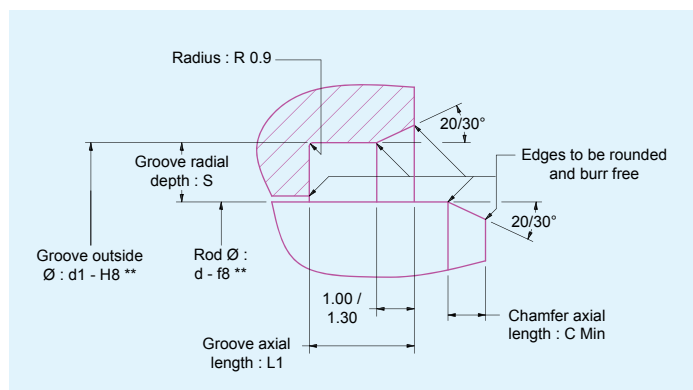

#### Notes

- 1) For existing and new applications housing dimensions are to be based on BS ISO 6195, Type B.
- 2) Surface roughness and finish requirements: See *Machining information section*.
- 3) \*\* Tolerances in accordance with BS EN ISO 286-1 and BS EN ISO 286-2: See Appendix V.

#### Lionsele® W2 housing dimensions for Type B wiper

Based on BS ISO 6195 Tables 2 and 7

Rod Ø <sup>A)</sup> (mm)	Radial depth (mm)	Outside Ø (mm)	Axial length (mm)	Wiper length (mm)	Chamfer length (mm)
d f8**	S	Ø d1 H8**	L1 + 0.5 ; - 0	L2 Max	C Min
4.00	4.00	12.00	5.00	8.00	2.00
5.00					
6.00					
8.00					
10.00					
12.00	5.00	22.00	7.00	11.00	2.50
14.00					
16.00					
18.00					
20.00					
22.00					
25.00					
28.00					
32.00					
36.00					
40.00					
45.00					
50.00					
56.00					
63.00					
70.00					
80.00					
90.00					
100.00	7.50	115.00	9.00	13.00	4.00
110.00					
125.00					
140.00					
160.00					
180.00					
200.00					
220.00	10.00	240.00	12.00	16.00	5.00
250.00					
280.00					
320.00					
360.00					

<sup>A)</sup> See ISO 3320 and BS ISO 5597

\*\* All tolerances in accordance with BS EN ISO 286-1 and BS EN ISO 286-2

# Appendix Q

## Lionsele® W3 wiper preferred housing designs

### Design dimensional nomenclature

#### Housing arrangement

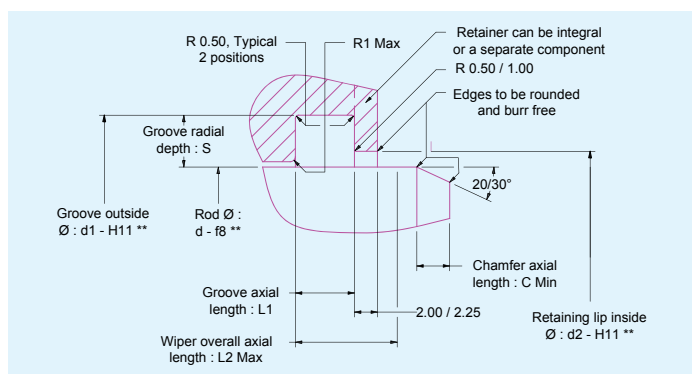

#### Notes

- 1) For existing and new applications housing dimensions are to be based on BS ISO 6195, Type C.
- 2) Surface roughness and finish requirements: See *Machining information* section.
- 3) \*\* Tolerances in accordance with BS EN ISO 286-1 and BS EN ISO 286-2: See Appendix V.

#### Lionsele® W3 housing dimensions for Type C wiper

Based on BS ISO 6195 Tables 3 and 7

Rod Ø <sup>A), B)</sup> (mm)	Radial depth (mm)	Outside Ø (mm)	Axial length (mm)	Wiper length (mm)	Retainer Ø (mm)	Radius (mm)	Chamfer length (mm)		
d f8**	S	Ø d1 H11**	L1	L2 Max	Ø d2 H11**	R1 Max	C Min		
4.00	3.00	10.00	4.00 + 0 + 0.20	7.00	6.50	0.30	2.00		
5.00		11.00			7.50				
6.00		12.00			8.50				
8.00		14.00			10.50				
10.00		16.00			12.50				
12.00 <sup>C)</sup>		18.00			14.50				
14.00 <sup>C)</sup>		20.00			16.50				
16.00		22.00			18.50				
18.00 <sup>C)</sup>		24.00			20.50				
20.00		26.00			22.50				
22.00 <sup>C)</sup>		28.00			24.50				
25.00	4.00	31.00	5.00 + 0 + 0.20	8.00	27.50	0.30	2.00		
28.00 <sup>C)</sup>		36.00			31.00				
32.00		40.00			35.00				
36.00 <sup>C)</sup>		44.00			39.00				
40.00		48.00			43.00				
45.00 <sup>C)</sup>		53.00			48.00				
50.00		58.00			53.00				
56.00 <sup>C)</sup>		66.00			59.00				
63.00		73.00			66.00				
70.00 <sup>C)</sup>		80.00			73.00				
80.00		90.00			83.00				
90.00 <sup>C)</sup>	100.00	93.00							
100.00	5.00	115.00	6.00 + 0 + 0.20	9.70	103.00	0.30	2.50		
110.00 <sup>C)</sup>		125.00			114.00				
125.00		140.00			129.00				
140.00 <sup>C) D)</sup>		155.00			144.00				
160.00		175.00			164.00				
180.00 <sup>D)</sup>		195.00			184.00				
200.00		215.00			204.00				
220.00 <sup>D)</sup>		240.00			226.00				
250.00		270.00			256.00				
280.00 <sup>D)</sup>		300.00			286.00				
320.00		340.00			326.00				
360.00 <sup>D)</sup>	380.00	366.00							
	10.00		12.00 + 0 + 0.30	18.00		0.60	5.00		

<sup>A)</sup> See ISO 3320 and BS ISO 5597

<sup>B)</sup> Split housings should be used for rod diameters up to and including 18mm

<sup>C)</sup> These sizes are recommended for use with cylinders conforming to BS ISO 6020-2 and BS ISO 10762

<sup>D)</sup> These sizes are recommended for use with cylinders conforming to BS ISO 6020-3

\*\* All tolerances in accordance with BS EN ISO 286-1 and BS EN ISO 286-2

# Appendix R

## Wyclip® scraper/wiper preferred housing designs

### Design dimensional nomenclature

#### Housing arrangement

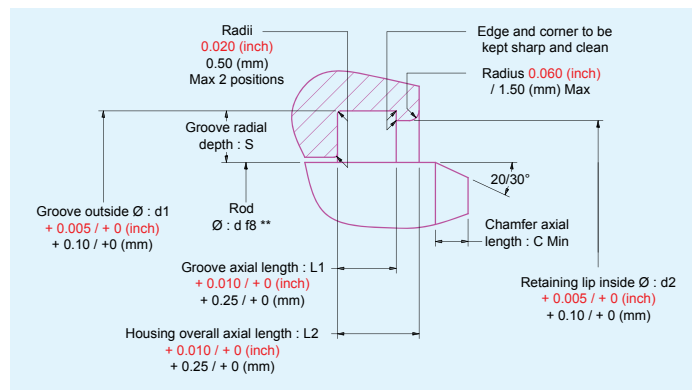

#### Notes

- 1) For all applications housing dimensions are to be in accordance with JW preferred housing dimensions.
- 2) Surface roughness and finish requirements: See *Machining information* section.
- 3) \*\* Tolerances in accordance with BS EN ISO 286-1 and BS EN ISO 286-2: See Appendix V.

#### Wyclip® preferred housing dimensions — JW Chart 62 Inch sizes (inch)

Shaft $\varnothing - d$ f8 **	Housing groove O/D - d1	Retaining lip $\varnothing - d2$	Nominal radial depth - S	Housing groove axial length - L1	Overall housing axial length - L2	Chamfer axial length - C Min
1/4	5/8	9/16	3/16	11/64	1/4	1/16
3/8	3/4	11/16				
1/2	7/8	13/16				
5/8	1	15/16				
3/4	1 1/4	1 3/16				
7/8	1 3/8	1 5/16				
1	1 1/2	1 7/16				
1 1/8	1 5/8	1 9/16				
1 1/5	1 2/3	1 5/8				
1 1/4	1 1/4	1 11/16				
1 3/8	1 7/8	1 13/16				
1 1/2	2	1 15/16				
1 5/8	2 1/8	2 1/16	1/14	15/64	11/32	3/32
1 3/4	2 1/4	2 3/16				
2	2 1/2	2 7/16				
2 1/4	2 3/4	2 11/16				
2 3/8	2 7/8	2 13/16				
2 1/2	3	2 15/16				
2 5/8	3 1/8	3 1/16				
2 3/4	3 1/4	3 3/16				
3	3 1/2	3 7/16				
3 1/4	3 3/4	3 11/16				
3 3/8	3 7/8	3 13/16				
3 1/2	4	3 15/16				
3 3/4	4 1/4	4 3/16	5/16	7 9/16	1/8	
4	4 1/2	4 7/16				
4 3/8	4 7/8	4 13/16				
4 1/2	5	4 15/16				
4 3/4	5 1/4	5 3/16				
4 7/8	5 3/8	5 5/16				
5	5 1/2	5 7/16				
5 1/2	6 1/8	6 1/16				
6	6 5/8	6 9/16				
6 1/2	7 1/8	7 1/16				
7	7 5/8	7 9/16				

#### Wyclip® preferred housing dimensions — JW Chart 67 Metric sizes (mm)

Shaft $\varnothing - d$ f8 **	Housing groove O/D - d1	Retaining lip $\varnothing - d2$	Nominal radial depth - S	Housing groove axial length - L1	Overall housing axial length - L2	Chamfer axial length - C Min
12.00	22.00	20.50	5.00	4.50	6.50	2.50
15.00	25.00	23.50				
16.00	26.00	24.50				
18.00	28.00	26.50				
20.00	33.00	31.50				
22.00	35.00	33.50				
25.00	38.00	36.50				
28.00	41.00	39.50				
30.00	43.00	41.50				
32.00	45.00	43.50				
36.00	49.00	47.50				
40.00	53.00	51.50				
45.00	58.00	56.50	6.50	6.00	8.50	3.00
50.00	63.00	61.50				
55.00	68.00	66.50				
56.00	69.00	67.50				
60.00	73.00	71.50				
63.00	76.00	74.50				
70.00	83.00	81.50				
75.00	88.00	86.50				
80.00	93.00	91.50				
85.00	98.00	96.50				
90.00	103.00	101.50				
95.00	108.00	106.50				
100.00	113.00	111.50				
105.00	118.00	116.50				
120.00	133.00	131.50	8.00			4.00
130.00	146.00	144.50				

\*\* Tolerances in accordance with BS EN ISO 286-1 & BS EN ISO 286-2

\*\* Tolerances in accordance with BS EN ISO 286-1 & BS EN ISO 286-2



# Appendix S Wiper Type L preferred housing designs

## Design dimensional nomenclature

### Housing arrangement

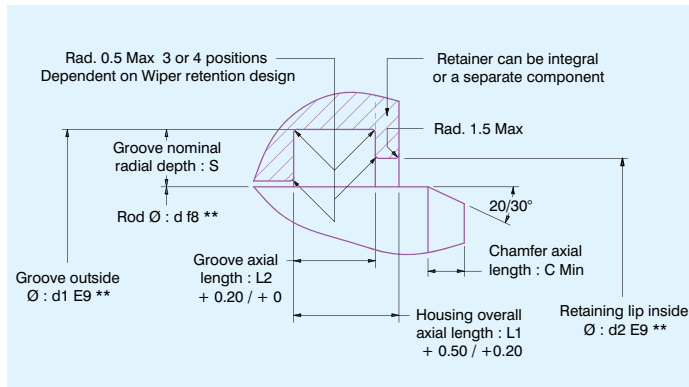

### Notes

- 1) All applications are to be in accordance with JW preferred housing dimensions.
- 2) Surface roughness and finish requirements: See *Machining information* section.
- 3) \*\* Tolerances in accordance with BS EN ISO 286-1 and BS EN ISO 286-2: See Appendix V.

### Wiper Type L (JW Chart 524) preferred housing dimensions Metric sizes (mm)

Shaft Ø d f8 **	Housing groove O/D d1 E9 **	Retainer lip Ø d2 E9 **	Nominal radial depth - S	Overall housing length - L1	Housing groove axial length - L2	Chamfer axial length - C Min
25.00	38.00	32.00				
26.00	39.00	33.00				
27.00	40.00	34.00				
28.00	41.00	35.00				
29.00	42.00	36.00				
30.00	43.00	37.00				
31.00	44.00	38.00				
32.00	45.00	39.00				
33.00	46.00	40.00				
34.00	47.00	41.00				
35.00	48.00	42.00				
36.00	49.00	43.00				
37.00	50.00	44.00				
38.00	51.00	45.00				
39.00	52.00	46.00				
40.00	53.00	47.00				
41.00	54.00	48.00				
42.00	55.00	49.00				
43.00	56.00	50.00				
44.00	57.00	51.00				
45.00	58.00	52.00				
46.00	59.00	53.00				
47.00	60.00	54.00				
48.00	61.00	55.00				
49.00	62.00	56.00	6.50	8.00	4.00	3.00
50.00	63.00	57.00				
52.00	65.00	59.00				
55.00	68.00	62.00				
56.00	69.00	63.00				
57.00	70.00	64.00				
58.00	71.00	65.00				
60.00	73.00	67.00				
62.00	75.00	69.00				
63.00	76.00	70.00				
65.00	78.00	72.00				
67.00	80.00	74.00				
70.00	83.00	77.00				
72.00	85.00	79.00				
75.00	88.00	82.00				
76.00	89.00	83.00				
77.00	90.00	84.00				
80.00	93.00	87.00				
82.00	95.00	89.00				
85.00	98.00	92.00				
87.00	100.00	94.00				
90.00	103.00	97.00				
95.00	108.00	102.00				
96.00	109.00	103.00				
100.00	113.00	107.00				

\*\* Tolerances in accordance with BS EN ISO 286-1 & BS EN ISO 286-2

Continued . . .

# Appendix S

## Wiper Type L preferred housing designs

**Wiper Type L (JW Chart 525) preferred housing dimensions  
Metric sizes (mm)**

Shaft Ø d f8 **	Housing groove O/D d1 E9 **	Retainer lip Ø d2 E9 **	Nominal radial depth - S	Overall housing length - L1	Housing groove axial length - L2	Chamfer axial length - C Min
105.00	120.00	113.00	7.50	12.00	7.00	4.00
110.00	125.00	118.00				
115.00	130.00	123.00				
120.00	135.00	128.00				
125.00	140.00	133.00				
128.00	143.00	136.00				
130.00	145.00	138.00				
135.00	150.00	143.00				
140.00	155.00	148.00				
145.00	160.00	153.00				
149.00	164.00	157.00				
150.00	165.00	158.00				
151.00	166.00	159.00				
153.00	168.00	161.00				
155.00	170.00	163.00				
160.00	175.00	168.00				
165.00	180.00	173.00				
170.00	185.00	178.00				
175.00	190.00	183.00				
180.00	195.00	188.00				
185.00	200.00	193.00				
190.00	205.00	198.00				
195.00	210.00	203.00				
200.00	215.00	208.00				
205.00	220.00	213.00				
210.00	225.00	218.00				
215.00	230.00	223.00				
220.00	235.00	228.00				
225.00	240.00	233.00				
230.00	245.00	238.00				
235.00	250.00	243.00				
240.00	255.00	248.00				
245.00	260.00	253.00				
250.00	265.00	258.00				

\*\* Tolerances in accordance with BS EN ISO 286-1 & BS EN ISO 286-2

**Wiper Type L (JW Chart 526) preferred housing dimensions  
Metric sizes (mm)**

Shaft Ø d f8 **	Housing groove O/D d1 E9 **	Retainer lip Ø d2 E9 **	Nominal radial depth - S	Overall housing length - L1	Housing groove axial length - L2	Chamfer axial length - C Min
210.00	228.00	219.00	9.00	15.00	7.50	5.00
250.00	268.00	259.00				
255.00	273.00	264.00				
260.00	278.00	269.00				
265.00	283.00	274.00				
270.00	288.00	279.00				
272.00	290.00	281.00				
273.00	291.00	282.00				
280.00	298.00	289.00				
285.00	303.00	294.00				
290.00	308.00	299.00				
300.00	318.00	309.00				
305.00	323.00	314.00				
310.00	328.00	319.00				
315.00	333.00	324.00				
320.00	338.00	329.00				
325.00	343.00	334.00				
330.00	348.00	339.00				
340.00	358.00	349.00				
350.00	368.00	359.00				
360.00	378.00	369.00				
370.00	388.00	379.00				
380.00	398.00	389.00				
390.00	408.00	399.00				
400.00	418.00	409.00				

\*\* Tolerances in accordance with BS EN ISO 286-1 & BS EN ISO 286-2

# Appendix T — Lionsele® B1 & B2 bearing strips preferred housing designs

## Design dimensional nomenclature

### Housing arrangement

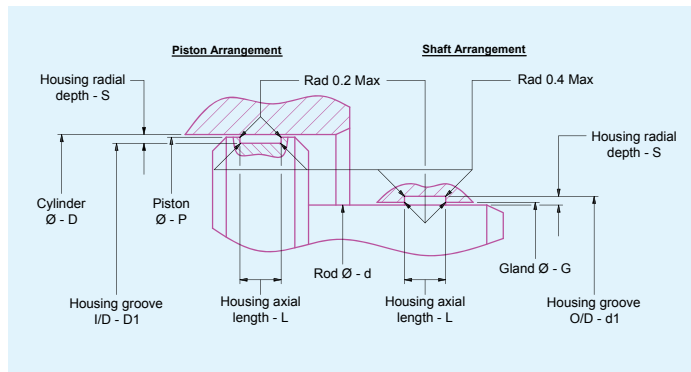

#### Notes

- 1) ## Cylinder  $\varnothing - D$  and Rod  $\varnothing - d$ : Tolerances to be in accordance with individual seal requirements as detailed in the individual seal housing dimensional details.
- 2) \*\* Piston  $\varnothing - P$  and Gland  $\varnothing - G$  shall be determined by the individual seal requirements for radial clearances and extrusion gaps as detailed in the individual seal housing dimensional details.
- 3) Surface roughness and finish requirements: See *Machining information* section.

### Split arrangements

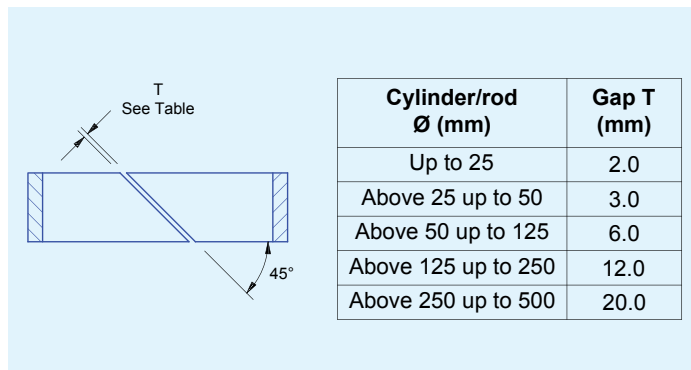

### Lionsele® B1 & B2 nominal housing dimensions

Based on BS ISO 10766 Table 1

Groove dimensions (mm)	
Axial length ; L	Radial depth ; S
4.00	1.55
5.60	2.50
9.70	
15.00	
25.00	4.00

### Housings for cut bearing rings for pistons/cylinders

Based on BS ISO 10766 Table 2

Cylinder bore $\varnothing - D$ ** (mm)	Housing groove dimensions (mm)				
	I/D - D1	Tolerance on D1	Axial length - L + 0 ; + 0.2	Radial depth - S Nominal	
16.00	11.00	- 0 ; - 0.05	5.60	2.50	
	12.90		4.00	1.55	
20.00	15.00		5.60	2.50	
	16.90		4.00	1.55	
25.00	20.00		5.60	2.50	
	21.90		4.00	1.55	
32.00	27.00		5.60	2.50	
	28.90		4.00	1.55	
40.00	35.00		5.60	2.50	
	36.90		4.00	1.55	
50.00	45.00		5.60	2.50	
	46.90		4.00	1.55	
63.00	58.00		5.60	2.5	
	80.00		75.00		9.70
100.00			95.00		5.60
	9.70				
125.00	120.00		5.60		9.70
			9.70		
140.00	135.00		15.00		9.70
			9.70		
160.00	155.00	15.00	9.70		
		9.70			
180.00	175.00	15.00	9.70		
		9.70			
200.00	195.00	15.00	9.70		
		9.70			
220.00	215.00	15.00	9.70		
		9.70			
250.00	245.00	15.00	14.00		
		9.70			
280.00	275.00	- 0 ; - 0.08	25.00	4.00	
	272.00		25.00		
320.00	315.00		14.00	2.50	
	312.00		25.00	4.00	
360.00	355.00		14.00	2.50	
	352.00		25.00	4.00	
400.00	395.00		14.00	2.50	
	392.00		25.00	4.00	
450.00	445.00		14.00	2.50	
	442.00		25.00	4.00	
500.00	495.00		14.00	2.50	
	492.00		25.00	4.00	

\*\* Tolerance usually no more than H10 (BS EN ISO 286-1 & -2) and dependent on seal requirements for bore diameter tolerancing.

**Diametral Clearance:** In piston applications this is the difference between the Cylinder bore  $\varnothing - D$  and Piston  $\varnothing - P$  and it controls the level of the extrusion gap (see Housing arrangement). It may be further increased by the expansion of the cylinder from internal pressure. The level of the extrusion gap is critical in achieving satisfactory and long term sealing performance; it should be the subject of consultations between the housing designer and James Walker.

Continued . . .

# Appendix T — Lionsele® B1 & B2 bearing strips preferred housing designs

## Housings for cut bearing rings for rods/shafts

Based on BS ISO 10766 Table 3

Rod / Shaft Ø - d ; f8 ** (mm)	Housing groove dimensions (mm)															
	O/D - d1	Tolerance on d1	Axial length - L + 0 ; + 0.2	Radial depth - S Nominal												
12.00	15.10	+ 0 ; + 0.05	4.00	1.55												
14.00	17.10															
16.00	19.10															
18.00	21.10															
20.00	23.10															
22.00	25.10															
25.00	28.10		+ 0 ; + 0.08	5.60	2.50											
	30.00															
28.00	31.10			+ 0 ; + 0.08	4.00	1.55										
	33.00															
32.00	37.00				+ 0 ; + 0.08	5.60	2.50									
						9.70										
						9.70										
36.00	41.00					+ 0 ; + 0.08		5.60	2.50							
		9.70														
40.00	45.00	+ 0 ; + 0.08						5.60		2.50						
								9.70								
45.00	50.00							+ 0 ; + 0.08			5.60	2.50				
											9.70					
50.00	55.00										+ 0 ; + 0.08		5.60	2.50		
			9.70													
56.00	61.00		+ 0 ; + 0.08										5.60		2.50	
				9.70												
63.00	68.00			+ 0 ; + 0.08									5.60			2.50
					9.70											
70.00	75.00				+ 0 ; + 0.08		5.60						2.50			
							9.70									
80.00	85.00					+ 0 ; + 0.08	15.00		2.50							
							9.70									
90.00	95.00	+ 0 ; + 0.08					15.00			2.50						
							9.70									
100.00	105.00						+ 0 ; + 0.08	15.00				2.50				
								9.70								
110.00	115.00							+ 0 ; + 0.08			15.00			2.50		
											9.70					
125.00	130.00		+ 0 ; + 0.08								15.00				2.50	
											9.70					
140.00	145.00			+ 0 ; + 0.08							15.00					2.50
											9.70					
160.00	165.00				+ 0 ; + 0.08						15.00		2.50			
											9.70					
180.00	185.00					+ 0 ; + 0.08			15.00		2.50					
									25.00							
200.00	205.00	+ 0 ; + 0.08							15.00	2.50						
									25.00							
220.00	225.00						+ 0 ; + 0.08		15.00			2.50				
									25.00							
250.00	255.00							+ 0 ; + 0.08	15.00					2.50		
									25.00							

Rod / Shaft Ø - d ; f8 ** (mm)	Housing groove dimensions (mm)				
	O/D - d1	Tolerance on d1	Axial length - L + 0 ; + 0.2	Radial depth - S Nominal	
280.00	285.00	+ 0 ; + 0.08	15.00	2.50	
	288.00		25.00		
320.00			325.00	15.00	2.50
	328.00		25.00	4.00	
360.00			385.00	15.00	4.00
	25.00			2.50	
	25.00			4.00	
360.00	388.00		+ 0 ; + 0.08	15.00	4.00
		25.00		2.50	
360.00	388.00	+ 0 ; + 0.08		25.00	4.00
				25.00	

\*\* All tolerances in accordance with BS EN ISO 286-1 & BS EN ISO 286 -2

**Diametrical Clearance:** In piston applications this is the difference between the Rod Ø - d and Gland Inside Ø - G and it controls the level of the extrusion gap (see Housing arrangement). The level of the extrusion gap is critical in achieving satisfactory and long term sealing performance; it should be the subject of consultations between the housing designer and James Walker.

Appendix T

# Appendix U

## Specifications & standards

Reference	Title
BS 1134	Assessment of surface texture - Guidance and general information
BS 4193-2/ISO 833	Hardmetal insert tooling. Specifications for dimensions of indexable hardmetal (carbide) inserts with rounded corners, without fixing hole
BS EN ISO 286-1	ISO system of limits and fits - Part 1: Bases of tolerance and fits
BS EN ISO 286-2	ISO system of limits and fits - Part 2: Tables of standard tolerance grades and limit deviations for holes and shafts
BS EN ISO 1302	Geometrical Product Specifications (GPS) - Indication of surface texture in technical product documentation
BS EN ISO 3274	Geometrical Product Specifications (GPS) - Surface texture: Profile method - Nominal characteristics of contact (stylus) instruments
BS EN ISO 4287	Geometrical Product Specifications (GPS) - Profile method: Terms, definitions and surface texture parameters
BS EN ISO 4288	Geometrical Product Specifications (GPS) - Profile method: Rules and procedures for the assessment of surface texture
BS EN ISO 8785	Geometrical Product Specifications (GPS) - Surface imperfections - Terms, definitions and parameters
BS EN ISO 885	General purpose bolts and screws - Metric sizes - Radii under the head
BS ISO 5597	Hydraulic Fluid Power - Cylinders. Dimensions and tolerances of housings for single-acting piston and rod seals in reciprocating applications
BS ISO 6020-1	Hydraulic Fluid Power - Mounting Dimensions for Single Rod Cylinders, 16 MPa (160 bar) series - Medium series
BS ISO 6020-2	Hydraulic Fluid Power - Mounting Dimensions for Single Rod Cylinders, 16 MPa (160 bar) series - Compact series
BS ISO 6020-3	Hydraulic Fluid Power - Mounting Dimensions for Single Rod Cylinders, 16 MPa (160 bar) series - Compact series with bores from 250mm to 500mm
BS ISO 6195	Fluid Power Systems and Components - Cylinder - Rod Wiper-Ring Housings in Reciprocating Applications - Dimensions and Tolerances
BS ISO 6547	Hydraulic Fluid Power - Cylinders - Piston Seal Housings Incorporating Bearing Rings - Dimensions and Tolerances
BS ISO 7425-1	Hydraulic Fluid Power - Housings for elastomer-energized, plastic-faced seals - Dimensions and Tolerances - Part 1 : Piston Seal Housings
BS ISO 7425-2	Hydraulic Fluid Power - Housings for elastomer-energized, plastic-faced seals - Dimensions and Tolerances - Part 2 : Rod Seal Housings
BS ISO 10766	Hydraulic Fluid Power - Cylinders - Housing dimensions for rectangular-section-cut bearing rings for pistons and rods
BS ISO 13715	Technical drawings - Edges of undefined shapes - Vocabulary and indications
ISO 468	Surface Roughness - Parameters, their values and general rules for specifying requirements
ISO 883	See BS 4193-2 above
ISO 3320	Fluid power systems and components - Cylinder bores and piston rod diameters - Metric Series
ISO 10762	Hydraulic fluid power - Cylinder mounting dimensions - 10MPa (100bar) series

# Appendix V

## Rod/shaft & tube/cylinder tolerances

These tables are based on and extracted from BS EN ISO 286-1 and BS EN ISO 286-2

Rod / shaft Ø (mm)		Tolerances for rods / shafts (mm)									
		e8		f8		h9		h10		h11	
Above	Up to and including	Lower limit Minus (-)	Upper limit Minus (-)	Lower limit Minus (-)	Upper limit Minus (-)	Lower limit Minus (-)	Upper limit Minus (-)	Lower limit Minus (-)	Upper limit Minus (-)	Lower limit Minus (-)	Upper limit Minus (-)
3.00	6.00	0.038	0.020	0.028	0.010	0.030	0	0.048	0	0.075	0
6.00	10.00	0.047	0.025	0.035	0.013	0.036	0	0.058	0	0.090	0
10.00	18.00	0.059	0.032	0.043	0.016	0.043	0	0.070	0	0.110	0
18.00	30.00	0.073	0.040	0.053	0.020	0.052	0	0.084	0	0.130	0
30.00	50.00	0.089	0.050	0.064	0.025	0.062	0	0.100	0	0.160	0
50.00	80.00	0.106	0.060	0.076	0.030	0.074	0	0.120	0	0.190	0
80.00	120.00	0.126	0.072	0.090	0.036	0.087	0	0.140	0	0.220	0
120.00	180.00	0.148	0.085	0.106	0.043	0.100	0	0.160	0	0.250	0
180.00	250.00	0.172	0.100	0.122	0.050	0.115	0	0.185	0	0.290	0
250.00	315.00	0.191	0.110	0.137	0.056	0.130	0	0.210	0	0.320	0
315.00	400.00	0.214	0.125	0.151	0.062	0.140	0	0.230	0	0.360	0
400.00	500.00	0.232	0.135	0.185	0.068	0.155	0	0.250	0	0.400	0

Tube / cylinder Ø (mm)		Tolerances for tubes / cylinders (mm)									
		E8		H8		H9		H10		H11	
Above	Up to and including	Lower limit Plus (+)	Upper limit Plus (+)	Lower limit Plus (+)	Upper limit Plus (+)	Lower limit Plus (+)	Upper limit Plus (+)	Lower limit Plus (+)	Upper limit Plus (+)	Lower limit Plus (+)	Upper limit Plus (+)
3.00	6.00	0.020	0.038	0	0.018	0	0.030	0	0.048	0	0.075
6.00	10.00	0.025	0.047	0	0.022	0	0.036	0	0.058	0	0.090
10.00	18.00	0.032	0.059	0	0.027	0	0.043	0	0.070	0	0.110
18.00	30.00	0.040	0.073	0	0.033	0	0.052	0	0.084	0	0.130
30.00	50.00	0.050	0.089	0	0.039	0	0.062	0	0.100	0	0.160
50.00	80.00	0.060	0.106	0	0.046	0	0.074	0	0.120	0	0.190
80.00	120.00	0.072	0.125	0	0.054	0	0.087	0	0.140	0	0.220
120.00	180.00	0.085	0.148	0	0.063	0	0.100	0	0.160	0	0.250
180.00	250.00	0.100	0.172	0	0.072	0	0.115	0	0.185	0	0.290
250.00	315.00	0.110	0.191	0	0.081	0	0.130	0	0.210	0	0.320
315.00	400.00	0.125	0.214	0	0.089	0	0.140	0	0.230	0	0.360
400.00	500.00	0.135	0.273	0	0.097	0	0.155	0	0.250	0	0.400

Appendix V

# Appendix W

## Piston seal housings

Table 1 — Based on BS ISO 5597 Tables 2,3 and 7

Nominal dimensions for piston seal housings (except where cylinders conform to BS ISO 6020-2; see Table 2)

**Notes:**

- 1) Chevron® & Lofilm®: use housing axial length **L3 Long** only.  
 2) Solosele® G, Lionsele® U1 & U3: use housing axial lengths **L1 Short** and **L2 Medium** only.  
 3) Solosele® S: use housing axial length **L2 Medium** only.

Bore <sup>a</sup> Ø D H9 ** (mm)	Groove dimensions (mm)						Base radius R Max	Chamfer length C Min (mm)
	Radial depth S		Nominal inside Ø D1	Axial length <sup>b</sup> L ; + 0.25, - 0				
	Nominal	Actual		L1 Short	L2 Medium	L3 Long		
16.00	4.00	4.15 / 3.95	8.00	5.00	6.30	N/A	0.30	2.00
20.00			12.00					
25.00			17.00					
32.00	5.00	5.15 / 4.90	15.00	6.30	8.00	16.00	0.30	2.50
	4.00	4.15 / 3.95	24.00	5.00	6.30	N/A		2.00
40.00	5.00	5.15 / 4.90	22.00	6.30	8.00	16.00	0.30	2.50
	4.00	4.15 / 3.95	32.00	5.00	6.30	N/A		2.00
50.00	5.00	5.15 / 4.90	30.00	6.30	8.00	16.00	0.40	2.50
	7.50	7.70 / 7.40	40.00	9.50	12.50	25.00		4.00
63.00	5.00	5.15 / 4.90	53.00	6.30	8.00	16.00	0.30	2.50
	7.50	7.70 / 7.40	48.00	9.50	12.50	25.00	0.40	4.00
80.00	10.00	10.25 / 9.90	65.00	12.50	16.00	32.00	0.60	5.00
	7.50	7.70 / 7.40	60.00	9.50	12.50	25.00	0.40	4.00
90.00	10.00	10.25 / 9.90	75.00	12.50	16.00	32.00	0.60	5.00
	7.50	7.70 / 7.40	70.00	9.50	12.50	25.00	0.40	4.00
100.00	10.00	10.25 / 9.90	85.00	12.50	16.00	32.00	0.60	5.00
	7.50	7.70 / 7.40	80.00	9.50	12.50	25.00	0.40	4.00
110.00	10.00	10.25 / 9.90	95.00	12.50	16.00	32.00	0.60	5.00
	7.50	7.70 / 7.40	90.00	9.50	12.50	25.00	0.40	4.00
125.00	12.50	12.80 / 12.35	105.00	16.00	20.00	40.00	0.80	6.50
	10.00	10.25 / 9.90	100.00	12.50	16.00	32.00	0.60	5.00
140.00	12.50	12.80 / 12.35	115.00	16.00	20.00	40.00	0.80	6.50
	10.00	10.25 / 9.90	140.00	12.50	16.00	32.00	0.60	5.00
160.00	12.50	12.80 / 12.35	135.00	16.00	20.00	40.00	0.80	6.50
	15.00	15.35 / 14.80	175.00	20.00	25.00	50.00		7.50
200.00	12.50	12.80 / 12.35	195.00	16.00	20.00	40.00	0.80	6.50
	15.00	15.35 / 14.80	190.00	20.00	25.00	50.00		7.50
220.00	12.50	12.80 / 12.35	225.00	16.00	20.00	40.00	0.80	6.50
	15.00	15.35 / 14.80	220.00	20.00	25.00	50.00		7.50
250.00	12.50	12.80 / 12.35	250.00	20.00	25.00	50.00	0.80	7.50
	15.00	15.35 / 14.80	290.00					
280.00	20.00	20.40 / 19.80	330.00	25.00	32.00	63.00	1.00	10.00
320.00			360.00					
360.00			410.00					
400.00	20.00	20.40 / 19.80	460.00	25.00	32.00	63.00	1.00	10.00
450.00			460.00					
500.00	20.00	20.40 / 19.80	460.00	25.00	32.00	63.00	1.00	10.00

See page 80 for BS ISO 5597 piston/cylinder housing nomenclature.

<sup>a</sup> See ISO 3320<sup>b</sup> The application of axial lengths in Table 1 (Short, Medium & Long) depends on respective working conditions

\*\* All tolerances in accordance with BS EN ISO 286-1 and BS EN ISO 286-2

# Appendix W

## Piston seal housings

Table 2 — based on BS ISO 5597 Tables 2, 4 and 7

Nominal dimensions for piston seal housings for use where cylinders conform to BS ISO 6020-2

Note: Use with Solosele® G, Lionsele® U1 & U3 only.

Bore <sup>A</sup> Ø D H9 ** (mm)	Groove dimensions (mm)			Base radius R Max <sup>B</sup>	Chamfer length C Min (mm)
	Radial depth S	Nominal inside Ø D1	Axial length L + 0.25, - 0		
25.00	3.50	18.00	5.60	0.50	2.00
32.00		25.00			
40.00	4.00	32.00	6.30		2.50
50.00		42.00			
63.00		55.00			
80.00	5.00	70.00	7.50		2.50
100.00		90.00			
125.00	7.50	110.00	10.60		4.00
160.00		145.00			
200.00		185.00			

<sup>A</sup> See ISO 6020-2

<sup>B</sup> This specific dimension permits the use of tools conforming to BS ISO 885

\*\* All tolerances in accordance with BS EN ISO 286-1 and BS EN ISO 286-2

Any relaxation of tolerances on one housing component will necessitate compensating tighter tolerances on another component to maintain the required radial seal space limits.

### Design dimensional nomenclature

#### BS ISO 5597 piston/cylinder housing

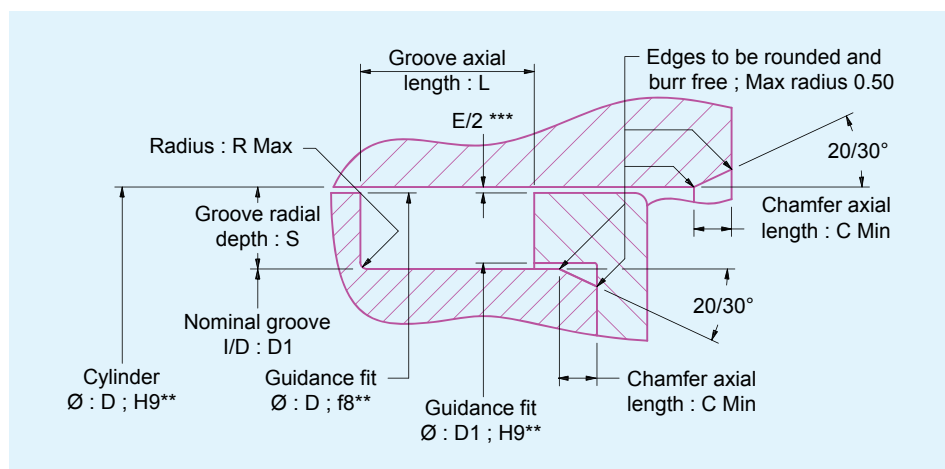

#### Notes

- 1) E/2 \*\*\*: Radial clearances and extrusion gaps (part concentric): See *Machining information section*.
- 2) Surface roughness and finish requirements: See *Machining information section*.
- 3) \*\* All tolerances in accordance with BS EN ISO 286-1 and BS EN ISO 286-2.



# Appendix W

## Rod seal housings

Table 3 — Based on BS ISO 5597 Tables 2, 5 and 7

Nominal dimensions for rod seal housings (except where cylinders conform to BS ISO 6020-2; see Table 4)

**Notes:**

- 1) Chevron® & Lofilm®: use housing axial length **L3 Long** only.
- 2) Solosele® G, Lionsele® U1 & U2: use housing axial length **L1 Short** and **L2 Medium** only.
- 3) Solosele® S: use housing axial length **L2 Medium** only.

RodA Ø d f8 ** (mm)	Groove dimensions (mm)						Base radius R Max	Chamfer length C Min (mm)
	Radial depth S		Nominal outside Ø d1	Axial length <sup>a</sup> L ; + 0.25, - 0				
	Nominal	Actual		L1 Short	L2 Medium	L3 Long		
6.00	4.00		14.00					
8.00	4.00	4.15 / 3.95	16.00	5.00	6.30	14.50	2.00	
10.00	4.00		18.00					
	5.00	5.15 / 4.90		N/A	8.00	16.00	2.50	
12.00	4.00	4.15 / 3.95	20.00	6.00	6.30	14.50	2.00	
	5.00	5.15 / 4.90		N/A	8.00	16.00	2.50	
14.00	4.00	4.15 / 3.95	22.00	6.00	6.30	14.50	2.00	
	5.00	5.15 / 4.90		N/A	8.00	16.00	2.50	
16.00	4.00	4.15 / 3.95	24.00	6.00	6.30	14.50	2.00	
	5.00	5.15 / 4.90		N/A	8.00	16.00	2.50	
18.00	4.00	4.15 / 3.95	26.00	6.00	6.30	14.50	2.00	
	5.00	5.15 / 4.90		N/A	8.00	16.00	2.50	
20.00	4.00	4.15 / 3.95	28.00	6.00	6.30	14.50	2.00	
	5.00	5.15 / 4.90		N/A	8.00	16.00	2.50	
22.00	4.00	4.15 / 3.95	30.00	6.00	6.30	14.50	2.00	
	5.00	5.15 / 4.90		N/A	8.00	16.00	2.50	
25.00	4.00	4.15 / 3.95	32.00	6.00	6.30	14.50	2.00	
				N/A	8.00			
	5.00	5.15 / 4.90	35.00	6.30	8.00	16.00	2.50	
28.00	7.50	7.70 / 7.40	43.00	N/A	12.50	25.00	0.40	
	5.00	5.15 / 4.90	42.00	6.30	8.00	16.00	0.30	
32.00	7.50	7.70 / 7.40	47.00	N/A	12.50	25.00	0.40	
	5.00	5.15 / 4.90	46.00	6.30	8.00	16.00	0.30	
36.00	7.50	7.70 / 7.40	51.00	N/A	12.50	25.00	0.40	
	5.00	5.15 / 4.90	50.00	6.30	8.00	16.00	0.30	
40.00	7.50	7.70 / 7.40	55.00	N/A	12.50	25.00	0.40	
	5.00	5.15 / 4.90		6.30	8.00	16.00	0.30	
45.00	7.50	7.70 / 7.40	60.00	N/A	12.50	25.00	0.40	
	5.00	5.15 / 4.90		6.30	8.00	16.00	0.30	
50.00	7.50	7.70 / 7.40	65.00	N/A	12.50	25.00	0.40	
	5.00	5.15 / 4.90	71.00	9.50	12.50	25.00	0.40	
56.00	10.00	10.25 / 9.90	76.00	N/A	16.00	32.00	0.60	
	7.50	7.70 / 7.40	78.00	9.50	12.50	25.00	0.40	
63.00	10.00	10.25 / 9.90	83.00	N/A	16.00	32.00	0.60	
	7.50	7.70 / 7.40	85.00	9.50	12.50	25.00	0.40	
70.00	10.00	10.25 / 9.90	90.00	N/A	16.00	32.00	0.60	
	7.50	7.70 / 7.40	95.00	9.50	12.50	25.00	0.40	
80.00	10.00	10.25 / 9.90	100.00	N/A	16.00	32.00	0.60	
	7.50	7.70 / 7.40	105.00	9.50	12.50	25.00	0.40	
90.00	10.00	10.25 / 9.90	110.00	N/A	16.00	32.00	0.60	
	12.50	12.80 / 12.35	120.00	12.50	16.00	32.00	0.60	
100.00	10.00	10.25 / 9.90	125.00	N/A	20.00	40.00	0.80	
	12.50	12.80 / 12.35	130.00	12.50	16.00	32.00	0.60	
110.00	10.00	10.25 / 9.90	135.00	N/A	20.00	40.00	0.80	
	12.50	12.80 / 12.35	145.00	12.50	16.00	32.00	0.60	
125.00	10.00	10.25 / 9.90	150.00	N/A	20.00	40.00	0.80	
	12.50	12.80 / 12.35	160.00	12.50	16.00	32.00	0.60	
140.00	10.00	10.25 / 9.90	165.00	N/A	20.00	40.00	0.60	
	12.50	12.80 / 12.35	185.00	16.00	20.00	40.00	6.50	
160.00	15.00	15.35 / 14.80	190.00	N/A	25.00	50.00	7.50	
	12.50	12.80 / 12.35	201.00	16.00	20.00	40.00	6.50	
180.00	15.00	15.35 / 14.80	210.00	N/A	25.00	50.00	7.50	
	12.50	12.80 / 12.35	225.00	16.00	20.00	40.00	6.50	
200.00			230.00	N/A				
			250.00					
220.00	15.00	15.35 / 14.80	280.00	20.00	25.00	50.00	7.50	
			310.00					
250.00			360.00					
280.00			400.00					
320.00	20.00	20.40 / 19.80		25.00	32.00	63.00	1.00	
360.00							10.00	

See page 82 for BS ISO 5597 shaft/gland housing nomenclature.

<sup>a</sup> See ISO 3320<sup>b</sup> The application of axial lengths in Table 3 (Short, Medium & Long) depends on respective working conditions

\*\* All tolerances in accordance with BS EN ISO 286-1 and BS EN ISO 286-2

# Appendix W

## Rod seal housings

Table 4 — Based on BS ISO 5597 Tables 2, 6 and 7

Nominal dimensions for rod seal housings for use where cylinders conform to BS ISO 6020-2

Note: Use with Solosele® G, Lionsele® U1 & U2 only.

Rod $\varnothing d^A$ f8** (mm)	Groove dimensions (mm)			Chamfer length C Min (mm)	
	Radial depth S	Nominal outside $\varnothing d1$	Axial length L + 0.25, - 0		
12.00	3.65 / 3.45	19.00	5.60	2.00	
14.00		21.00			
18.00		25.00			
22.00		29.00			
28.00	4.15 / 3.95	36.00	6.30		
36.00		44.00			
45.00		53.00			
56.00	5.15 / 4.90	66.00	7.50		2.50
70.00		80.00			
90.00		100.00			
110.00	7.70 / 7.40	125.00	10.60	4.00	
140.00		155.00			

<sup>A</sup> See BS ISO 6020-2

<sup>B</sup> This specific dimension permits the use of tools conforming to BS ISO 885

\*\* All tolerances in accordance with BS EN ISO 286-1 and BS EN ISO 286-2

Any relaxation of tolerances on one housing component will necessitate compensating tighter tolerances on another component to maintain the required radial seal space limits.

### Design dimensional nomenclature

#### BS ISO 5597 shaft/gland housing

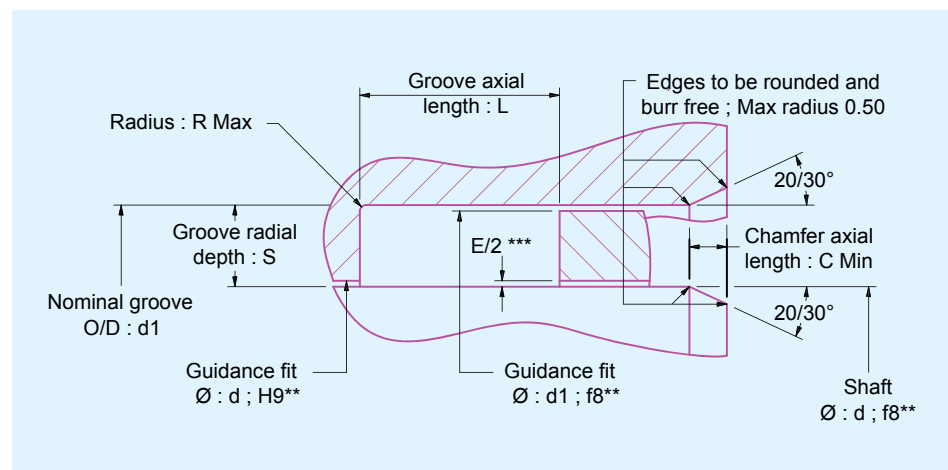

#### Notes

- 1) E/2 \*\*\*: Radial clearances and extrusion gaps (parts concentric): See *Machining information section*.
- 2) Surface roughness and finish requirements: See *Machining information section*.
- 3) \*\* All tolerances in accordance with BS EN ISO 286-1 and BS EN ISO 286-2.

# Technical guides

These guides give detailed information on many of the sealing products and services supplied by James Walker. Please ask for your copies, or visit our website [www.jameswalker.biz](http://www.jameswalker.biz) where many of them can be downloaded in pdf format.

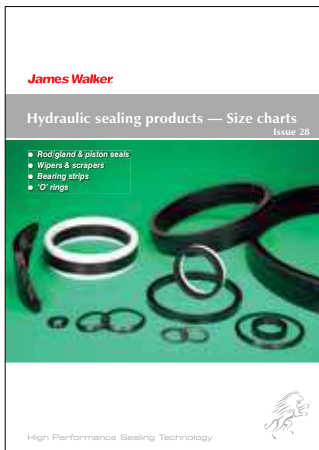

Hydraulic sealing products — Size charts (pdf only)

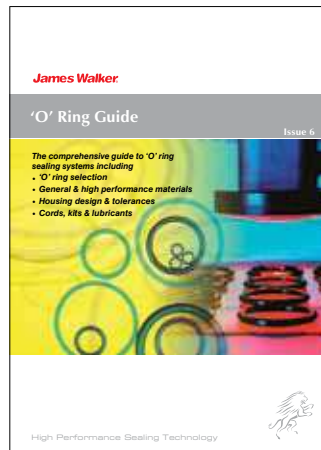

'O' rings

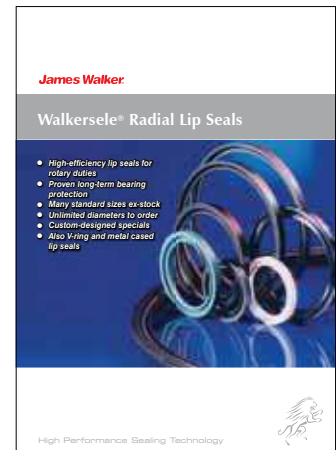

Walkersele® radial lip seals



RotaBolt® tension control fasteners



Gaskets & jointings

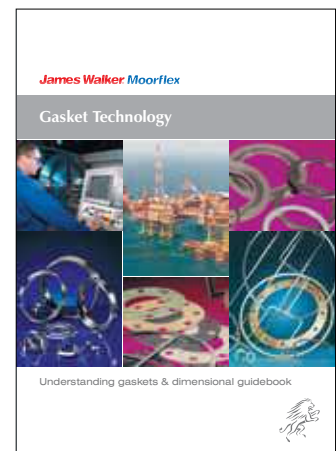

Gasket technology

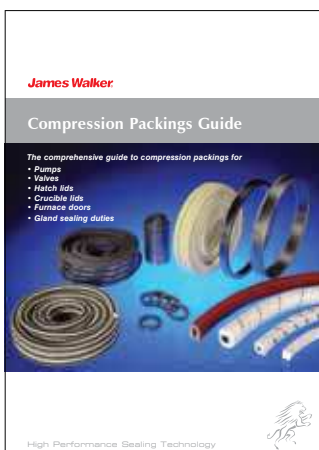

Compression packings

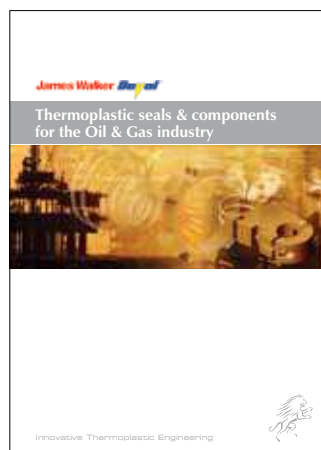

Thermoplastic seals & components for the Oil & Gas industry

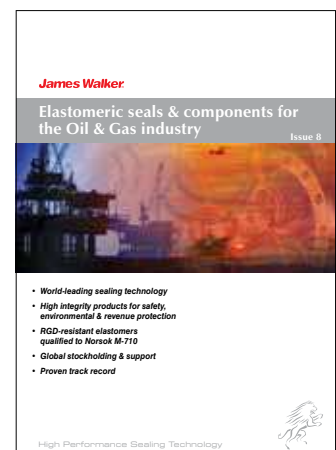

Elastomeric seals & components for the Oil & Gas industry

**Chevron®**  
Rod/gland & piston seal

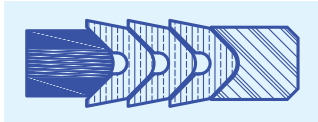

*Universally proven multi-lip packing*  
Details: P10-11 + Appendix A

**Lion® Expanding Packing**  
Rod/gland seal

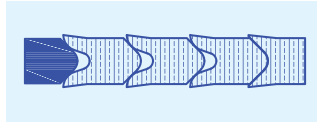

*Robust multi-lip packing*  
Details: P22-23 + Appendix G

**Solosele® SW**  
Piston seal

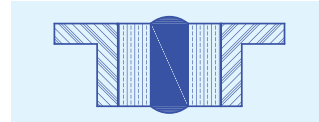

*Robust double-acting seal*  
Details: P33 + Appendix M

**Lionsele® W2**  
Wiper

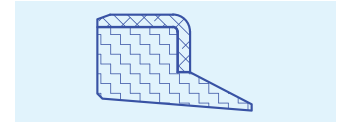

*Medium-to-heavy duty wiper*  
Details: P41 + Appendix P

**Solosele® G**  
Rod/gland & piston seal

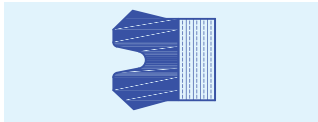

*Robust single element seal*  
Details: P12-13 + Appendix B

**Lofilm® HD**  
Rod/gland seal

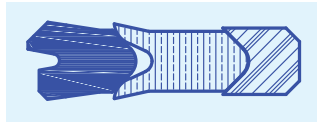

*For forging & extrusion presses*  
Details: P24-25 + Appendix H

**Lionsele® U3**  
Piston seal

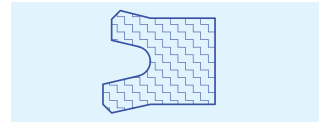

*Reduces risk of inter-seal pressure*  
Details: P34 + Appendix E

**Lionsele® W3**  
Wiper

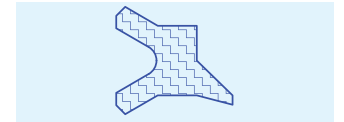

*Double-acting wiper*  
Details: P42 + Appendix Q

**Twinset**  
Rod/gland & piston seal

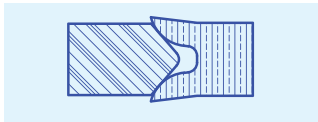

*Decades of duty on older plant*  
Details: P14-15 + Appendix C

**Lionsele® G**  
Rod/gland seal



*High performance, single-acting*  
Details: P26-27 + Appendix I

**Composite seals**  
Special duty product



*Custom-designed & manufactured*  
Details: P35 + Appendix N

**Wyclip®**  
Scraper/wiper

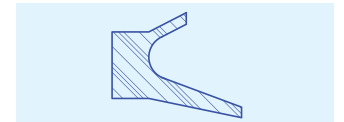

*Heavy-duty scraper/wiper*  
Details: P43 + Appendix R

**Lionsele® LF**  
Rod/gland & piston seal

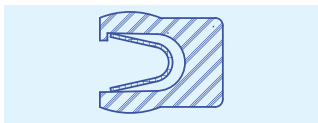

*Very low friction: smoothest operation*  
Details: P16-17 + Appendix D

**Lionsele® U2**  
Rod/gland seal

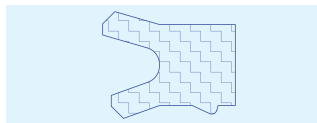

*Single-acting seal in polyurethane*  
Details: P28 + Appendix E

**Solosele® KB Hydro**  
Special duty product

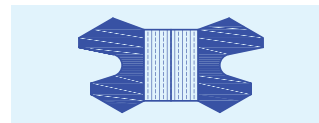

*Blade root seal for Kaplan turbines*  
Details: P36-37

**Wiper Type L**  
Wiper

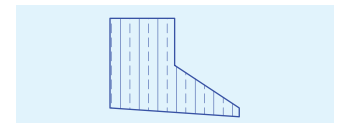

*Wiper for highly abrasive media*  
Details: P44 + Appendix S

**Lionsele® U1**  
Rod/gland & piston seal

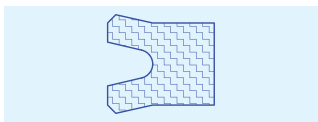

*For aggressive environments*  
Details: P18 + Appendix E

**Lionsele® SP**  
Piston seal

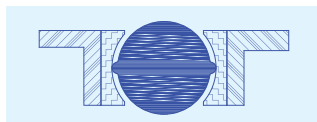

*Double-acting for spool-type pistons*  
Details: P29 + Appendix J

**Tube test seals**  
Special duty products

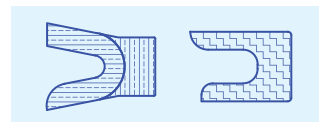

*For hydrostatic testing*  
Details: P38

**Lionsele® B1**  
Bearing strip

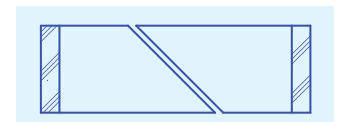

*Bronze-loaded PTFE for low friction*  
Details: P45 + Appendix T

**U-rings**  
Rod/gland & piston seals



*Variety of materials & designs*  
Details: P19

**Lionsele® P**  
Piston seal



*High performance, double-acting seal*  
Details: P30-31 + Appendix K

**Self-aligning Gland Rings**  
Special duty — optional feature

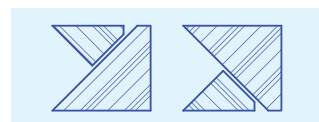

*For arduous conditions*  
Details: P39

**Lionsele® B2**  
Bearing strip

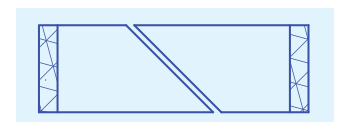

*For heavy-duty applications*  
Details: P46 + Appendix T

**Lofilm®**  
Rod/gland seal

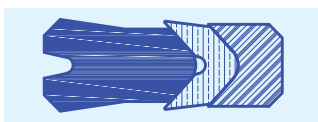

*Highly versatile multi-lip seal*  
Details: P20-21 + Appendix F

**Solosele® S**  
Piston seal

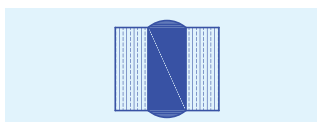

*For split-type piston heads*  
Details: P32 + Appendix L

**Lionsele® W1**  
Wiper

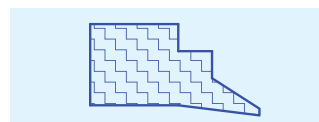

*Medium-duty wiper for sand & mud*  
Details: P40 + Appendix O

**Complex® Bellows**  
Ram protectors



*Robust, heavy-duty protection*  
Details: P47

'O' Rings Details: P48

## Alphabetical index of products

<b>Chevron®</b> — rod/gland & piston packing set .....	p10-11	<b>Lionsele® W3</b> — wiper.....	p42
<b>Comflex® Bellows</b> — ram protectors.....	p47	<b>Lofilm®</b> — rod/gland packing set .....	p20-21
<b>Composite seals</b> — special duty.....	p35	<b>Lofilm® HD</b> — rod/gland packing set .....	p24-25
<b>Lion® Expanding Packing</b> — rod/gland packing set... p22-23		<b>'O' rings</b> — highly versatile seals .....	p48
<b>Lionsele® B1</b> — bearing strip .....	p45	<b>Self-aligning Gland Rings</b> — optional feature.....	p39
<b>Lionsele® B2</b> — bearing strip .....	p46	<b>Shallex® (see Chevron®)</b> .....	p10-11
<b>Lionsele® G</b> — rod/gland seal.....	p26-27	<b>Solosele® G</b> — rod/gland & piston seal .....	p12-13
<b>Lionsele® LF</b> — rod/gland & piston seal .....	p16-17	<b>Solosele® KB Hydro</b> — special duty .....	p36-37
<b>Lionsele® P</b> — piston seal .....	p30-31	<b>Solosele® S</b> — piston seal.....	p32
<b>Lionsele® SP</b> — piston seal.....	p29	<b>Solosele® SW</b> — piston seal .....	p33
<b>Lionsele® U1</b> — rod/gland & piston seal.....	p18	<b>Tube test seals</b> — special duty.....	p38
<b>Lionsele® U2</b> — rod/gland seal.....	p28	<b>Twinsset</b> — rod/gland & piston packing set .....	p14-15
<b>Lionsele® U3</b> — piston seal.....	p34	<b>U-rings</b> — rod/gland & piston seals .....	p19
<b>Lionsele® W1</b> — wiper.....	p40	<b>Wiper Type L</b> — wiper .....	p44
<b>Lionsele® W2</b> — wiper.....	p41	<b>Wyclip®</b> — scraper/wiper.....	p43

## Trademark acknowledgements

James Walker acknowledges the following trademarks as mentioned in this guide. All other names bearing the ® symbol are registered trademarks of James Walker.

<b>Aflas®</b>	Asahi Glass
<b>Delrin®</b>	El du Pont de Nemours
<b>Kalrez®</b>	DuPont Performance Elastomers
<b>PEEK™</b>	Victrex plc
<b>Viton®</b>	DuPont Performance Elastomers

## General information

**Health warning:** If PTFE or fluoroelastomer (eg, FKM, FFKM, FEPM) products are heated to elevated temperatures, fumes will be produced which may give unpleasant effects, if inhaled. Whilst some fumes are emitted below 250°C from fluoroelastomers or below 300°C from PTFE, the effect at these temperatures is negligible. Care should be taken to avoid contaminating tobacco with particles of PTFE or fluoroelastomer, or with PTFE dispersion, which may remain on hands or clothing. Material Safety Data Sheets (MSDS) are available on request.

Information in this publication and otherwise supplied to users is based on our general experience and is given in good faith, but because of factors which are outside our knowledge and control and affect the use of products, no warranty is given or is to be implied with respect to such information. Unless governed by type approval or contract, specifications are subject to change without notice. Statements of operating limits quoted in this publication are not an indication that these values can be applied simultaneously.

To ensure you are working with the very latest product specifications, please consult the relevant section of the James Walker website: [www.jameswalker.biz](http://www.jameswalker.biz).

## James Walker companies worldwide

### James Walker & Co

Tel: +44 (0)1270 536000  
Fax: +44 (0)1270 536100  
Email: [csc@jameswalker.biz](mailto:csc@jameswalker.biz)

### James Walker Asia Pacific

Tel: +65 6777 9896  
Fax: +65 6777 6102  
Email: [sales.sg@jameswalker.biz](mailto:sales.sg@jameswalker.biz)

### James Walker Australia

Tel: +61 (0)2 9721 9500  
Fax: +61 (0)2 9721 9580  
Email: [sales.au@jameswalker.biz](mailto:sales.au@jameswalker.biz)

### James Walker Benelux

*(Belgium)*  
Tel: +32 3 820 7900  
Fax: +32 3 828 5484  
Email: [sales.be@jameswalker.biz](mailto:sales.be@jameswalker.biz)  
*(Netherlands)*  
Tel: +31 (0)186 633111  
Fax: +31 (0)186 633110  
Email: [sales.nl@jameswalker.biz](mailto:sales.nl@jameswalker.biz)

### James Walker Brasil

Tel: +55 21 2220 2152  
Fax: +55 21 2531 1704  
Email: [sales.br@jameswalker.biz](mailto:sales.br@jameswalker.biz)

### James Walker China

Tel: +86 21 6876 9351  
Fax: +86 21 6876 9352  
Email: [sales.cn@jameswalker.biz](mailto:sales.cn@jameswalker.biz)

### James Walker Deutschland

Tel: +49 (0)40 386 0810  
Fax: +49 (0)40 389 3230  
Email: [sales.de@jameswalker.biz](mailto:sales.de@jameswalker.biz)

### James Walker France

Tel: +33 (0)437 497 480  
Fax: +33 (0)437 497 483  
Email: [sales.fr@jameswalker.biz](mailto:sales.fr@jameswalker.biz)

### James Walker Iberica

Tel: +34 94 447 0099  
Fax: +34 94 447 1077  
Email: [sales.es@jameswalker.biz](mailto:sales.es@jameswalker.biz)

### James Walker Ireland

Tel: +353 (0)21 432 3626  
Fax: +353 (0)21 432 3623  
Email: [sales.ie@jameswalker.biz](mailto:sales.ie@jameswalker.biz)

### James Walker Italiana

Tel: +39 02 257 8308  
Fax: +39 02 263 00487  
Email: [sales.it@jameswalker.biz](mailto:sales.it@jameswalker.biz)

### James Walker Mfg (USA)

Tel: +1 708 754 4020  
Fax: +1 708 754 4058  
Email: [sales.jwmfg.us@jameswalker.biz](mailto:sales.jwmfg.us@jameswalker.biz)

### James Walker New Zealand

Tel: +64 (0)9 272 1599  
Fax: +64 (0)9 272 3061  
Email: [sales.nz@jameswalker.biz](mailto:sales.nz@jameswalker.biz)

### James Walker Norge

Tel: +47 22 706800  
Fax: +47 22 706801  
Email: [sales.no@jameswalker.biz](mailto:sales.no@jameswalker.biz)

### James Walker Oil & Gas (USA)

Tel: +1 281 875 0002  
Fax: +1 281 875 0188  
Email: [oilandgas@jameswalker.biz](mailto:oilandgas@jameswalker.biz)

### James Walker South Africa

Tel: +27 (0)31 304 0770  
Fax: +27 (0)31 304 0791  
Email: [sales.za@jameswalker.biz](mailto:sales.za@jameswalker.biz)

## James Walker & Co Ltd

Customer Support Centre  
1 Millennium Gate, Westmere Drive  
Crewe, Cheshire CW1 6AY, UK  
Tel: +44 (0)1270 536000  
Fax: +44 (0)1270 536100  
Email: [csc@jameswalker.biz](mailto:csc@jameswalker.biz)

[www.jameswalker.biz](http://www.jameswalker.biz)



CERTIFICATE No. FM 01269  
BS EN 9100:2003  
BS EN ISO 9001:2008